



Sehr geehrte Kunden,

dieser Katalog stellt die allgemeinen Ersatzteile für Europäische LKWs dar. Alle gezeigten Artikel in diesem Katalog sind austauschbar mit den Originalteilen, sind aber nicht Original. Die ursprünglichen Nummern sind nur zu Ihrer Information erwähnt.

Jedoch sind alle hierin beinhaltenen Beschreibungen und andere Anmerkungen Änderungen vorbehalten. Und wir übernehmen für Fehler in dieser Ausgabe keine Haftung.

Dear customer,

This catalogue represents general replacement parts for European trucks. All illustrated items in this catalogue are replaceable to the original ones, are not original. The original numbers has been mentioned for your information only.

However all descriptions and other remarks contained herein are subject to change without further notice. And we have no liability for any errors in this issue.

Cher clients

Ce catalogue représente les pièces de remplacement pour la plupart des camions européens. Tous les articles illustrés remplacent les originaux et ne sont pas originaux, les nombres originaux ont été mentionnés seulement pour votre Information.

Cependant toutes les descriptions et d'autres remarques contenues ci-dessus sont sujettes au changement sans préavis et nous n'avons aucune responsabilité pour erreurs dans cette issue.

MAN

RF No.	KTK No.	Page	RF No.	KTK No.	Page
04 35160 9207	08856	683/01	51 04301 0065	10400	606/01
04 35160 9704	08854	683/01	51 04301 0068	10401	606/01
04 35160 9706	08855	683/01	51 04301 0079	07614	606/01
04 35160 9812	08859	683/02	51 04301 0106	18754	606/01
06 02190 2610	07931	656/01	51 04302 0042	07612	615/01
06 11222 0218	09110	653/01	51 04902 0028	07596	600/04
06 56180 0709	07764	614/01	51 04902 0033	09059	600/01
06 56180 0715	06511	614/01	51 05405 5012	13324	605/01
06 56190 0706	06513	614/01	51 05503 6093	13226	604/02
06 56190 0709	06514	614/01	51 05601 0121	15822	604/01
06 56254 2203	06469	604/03	51 05805 5425	19232	608/01
06 56279 0362	15829	655/02	51 05805 5609	19233	608/01
06 56289 0064	09616	655/01	51 05901 0083	06489	604/03
06 56289 0319	12586	655/01	51 05901 0083	06498	604/03
06 56289 0371	12585	655/01	51 05904 0092	06508	600/05
06 56341 2122	07676	616/01	51 05904 0132	08511	600/05
06 56341 4254	09899	655/01	51 05904 0198	22413	600/06
06 71030 2111	07766	684/02	51 06402 0065	07674	616/01
06 71030 2112	07767	684/02	51 06500 6228	11036	617/02
06 71030 2114	07769	684/02	51 06500 6479	11038	617/03
06 71030 2121	07768	684/02	51 06500 6546	15627	617/01
06 76039 0006	07409	625/05	51 06500 6547	16223	617/01
36 27120 6005	19821	666/01	51 06500 6676	19498	617/01
51 00900 6558	08992	600/04	51 06500 7049	16139	617/01
51 00900 6570	08121	600/03	51 06500 7066	16222	617/01
51 00900 6630	15725	600/01	51 06520 0068	12095	617/02
51 00900 6652	22410	600/04	51 06601 0102	13220	618/01
51 00900 6680	22412	600/04	51 06601 0256	13221	618/01
51 01510 0094	14306	611/01	51 06601 0275	16455	618/01
51 01510 0206	09615	611/01	51 06901 0192	19911	617/02
51 01903 0166	07527	600/06	51 06903 0030	22408	617/03
51 01903 0251	06490	600/05	51 06903 0061	19909	617/02
51 02130 0013	08919	603/01	51 06904 0039	22407	616/01
51 02301 5210	21355	602/01	51 06904 0042	19910	617/02
51 02301 5210	21356	602/01	51 08901 0023	06492	600/03
51 02301 7295	11009	602/01	51 08901 0155	22414	600/02
51 02301 7410	10216	602/01	51 08901 0182	22406	612/01
51 02301 7440	21352	602/01	51 08901 0209	22405	612/01
51 02400 6044	15841	601/01	51 08902 0128	09840	605/01
51 02401 6141	15591	601/01	51 08902 0161	06483	600/03
51 02405 1003	10297	601/01	51 08902 0194	15729	600/01
51 03901 0298	09123	600/04	51 10108 0003	11633	605/01
51 03901 0338	15726	600/01	51 12101 7075	10126	625/02
51 03901 0338	15728	600/01	51 12101 7106	10127	625/02
51 03901 0342	06991	600/03	51 12101 7139	20306	626/01
51 03901 0382	15730	600/02	51 12101 7149	20307	626/01
51 03905 0104	06481	630/01	51 12150 0001	21387	625/02
51 03905 0134	08120	600/03	51 12150 7003	07622	625/03
51 03905 0157	15727	600/02	51 12501 7019	07635	625/01
51 03905 0161	16227	600/02	51 12501 7115	07640	625/04
51 03905 0187	22415	600/02	51 12503 0043	10084	625/02
51 04102 0065	07609	615/01	51 12505 0004	07620	625/01
51 04102 0075	07407	615/01	51 12505 0004	13536	625/02
51 04104 0021	11767	613/01	51 15101 7148	20308	626/01
51 04205 0019	11770	613/01	51 25921 6001	20496	674/01

MAN

RF No.	KTK No.	Page	RF No.	KTK No.	Page
51 26101 7092	10851	632/04	81 25101 6290	17834	636/01
51 26101 7148	10849	631/01	81 25101 6448	17837	636/01
51 26101 7201	10850	631/01	81 25101 6449	17836	636/01
51 26106 0007	14224	631/01	81 25101 6452	17839	636/02
51 27120 7038	19758	609/01	81 25101 6453	17838	636/01
51 27421 0009	11126	634/01	81 25101 6500	19140	636/02
51 27421 0216	19761	624/01	81 25101 6501	19141	636/02
51 54100 6046	15353	629/01	81 25101 6503	19143	636/02
51 54105 6008	10275	629/01	81 25101 6504	19142	636/02
51 54114 6045	18962	629/01	81 25101 6521	20028	636/03
51 54114 6073	15354	629/01	81 25101 6522	20027	636/03
51 54114 6081	15355	629/01	81 25225 6523	20023	636/05
51 54901 0001	06928	629/02	81 25225 6524	20014	636/05
51 54901 0004	06495	629/02	81 25225 6544	17844	636/05
51 90701 0103	07224	607/01	81 25225 6545	17843	636/04
51 90701 0104	07225	607/01	81 25229 6052	20024	636/06
51 91701 0274	07411	607/01	81 25229 6059	17846	636/05
51 91701 0386	09010	607/01	81 25229 6060	17845	636/05
51 93020 1005	11790	613/01	81 25260 6099	20029	636/04
51 95800 7431	16401	619/01	81 25260 6101	20013	636/03
51 95800 7435	16383	619/01	81 25320 6089	20026	636/03
51 96501 0261	09835	605/01	81 25320 6090	20025	636/03
51 96501 0262	10059	629/02	81 25320 6101	17840	636/04
51 96501 0264	07536	625/01	81 25320 6111	17842	636/04
51 96501 0265	07537	655/02	81 25320 6112	17841	636/04
51 96501 0295	07636	625/01	81 25505 0538	08906	637/01
51 96501 0295	07533	627/01	81 25505 0930	19827	637/01
51 96501 0305	06943	605/01	81 25509 0119	13865	633/01
51 96501 0348	12075	600/05	81 25509 0144	16445	633/01
51 96601 0575	22402	617/03	81 25601 6014	10848	631/01
51 98701 0065	06482	600/05	81 25921 6007	11522	632/03
51 98701 0114	09694	614/01	81 25921 6040	10839	632/02
81 06102 6203	16404	620/01	81 25921 6042	14220	632/03
81 06102 6208	17203	620/01	81 25921 6043	11523	632/04
81 06102 6209	16403	620/01	81 25937 0015	20688	635/01
81 06102 6218	19244	620/01	81 26106 6019	14228	631/01
81 06110 0025	12797	621/01	81 26203 0002	10840	632/01
81 06110 0027	12796	621/01	81 26203 6007	10842	632/01
81 06111 0018	11779	621/01	81 26203 6019	10841	632/01
81 06130 0083	19924	622/01	81 26204 0032	10844	632/03
81 06130 0197	20937	622/01	81 26207 6011	10845	632/03
81 11701 6046	10916	628/01	81 26212 0011	10835	632/02
81 11904 0014	07618	625/05	81 26212 0012	10836	632/02
81 12101 0001	07625	625/05	81 26225 6003	10834	632/01
81 12102 0002	07628	625/06	81 26401 6119	21839	638/01
81 12102 0002	07632	625/07	81 26401 6132	21840	638/01
81 12104 0003	07629	625/06	81 26411 6111	21841	638/01
81 12150 6003	07619	625/04	81 26485 6016	11114	669/01
81 12540 0008	07633	625/06	81 27120 0016	19816	609/01
81 12903 0001	07631	625/07	81 27421 0237	19760	624/01
81 12905 0055	07534	625/04	81 28601 6143	21842	640/01
81 15210 0084	17235	630/01	81 30300 6002	15363	641/01
81 15210 0086	17236	630/01	81 30300 6004	15364	641/02
81 15701 6003	13321	628/01	81 30550 0050	11034	641/01
81 25101 6289	17835	636/01	81 30550 0056	11024	641/01

MAN

RF No.	KTK No.	Page	RF No.	KTK No.	Page
81 30550 0060	11021	641/01	81 45502 0001	09115	653/01
81 30550 0063	11017	641/01	81 45503 0026	08818	653/02
81 30715 6135	19718	642/02	81 45504 0008	09114	653/03
81 30715 6152	19713	642/02	81 46610 6722	19186	675/01
81 30725 6014	10921	642/02	81 47101 6008	12264	676/01
81 30725 6031	10920	642/01	81 47101 6162	21663	676/01
81 30725 6062	16181	642/01	81 50110 0144	15793	664/01
81 30725 6065	16116	642/01	81 50110 0232	15794	664/01
81 30725 6084	20018	642/02	81 50211 0016	07738	659/01
81 32312 0153	06940	650/01	81 50301 0112	08547	660/01
81 32620 0039	19447	647/01	81 50301 0113	08546	660/01
81 32620 0045	19446	647/01	81 50301 0224	16854	660/01
81 32638 0005	14778	646/01	81 50301 0283	16853	660/01
81 32638 0006	14776	646/01	81 50400 6027	08946	667/01
81 32655 6129	19451	648/01	81 50410 6018	10074	667/01
81 32655 6181	19455	643/01	81 50410 6135	08947	667/02
81 32655 6182	19454	643/01	81 50610 6051	06526	662/01
81 32735 6011	10919	643/01	81 50610 6052	06527	662/01
81 32903 0116	06487	650/01	81 50610 6132	17085	662/01
81 35204 0015	10180	656/02	81 50610 6187	06646	661/01
81 35608 0024	07929	656/01	81 50610 6188	06647	661/01
81 35710 0044	07705	654/01	81 50610 6210	13571	661/02
81 35710 0045	07715	654/01	81 50610 6211	13570	661/02
81 35710 0067	15537	654/01	81 50610 6212	13256	661/02
81 35710 6009	15538	654/01	81 50610 6213	13255	661/01
81 39126 6006	10166	670/01	81 50610 6261	15820	661/01
81 39126 6020	13257	670/01	81 50610 6262	15821	661/01
81 39200 6016	10164	670/01	81 50803 0009	15542	663/01
81 39400 6107	13721	671/01	81 50803 0040	15543	663/01
81 39410 6019	14589	671/01	81 50820 5085	19377	665/01
81 39410 6020	13716	671/01	81 50820 5099	12091	665/01
81 39410 6023	16132	671/01	81 50820 6046	16365	665/01
81 41722 6013	22563	681/01	81 50820 6059	16364	665/01
81 43220 6108	20423	672/02	81 51101 6080	08251	667/05
81 43220 6206	12761	672/01	81 51113 0001	07744	668/01
81 43230 6061	19980	672/01	81 51113 0002	07745	668/01
81 43270 6040	08464	672/01	81 51113 0007	07748	668/02
81 43270 6080	11224	672/02	81 51113 0013	07743	668/01
81 43270 6105	21229	672/01	81 51113 0017	07750	668/02
81 43270 6119	20493	672/02	81 51113 0019	07742	668/01
81 43610 6061	20687	635/01	81 51113 0020	07749	668/02
81 43610 6117	18603	667/06	81 51220 6024	08873	682/02
81 43722 0019	15484	674/01	81 51220 6025	08874	682/02
81 43722 0021	15477	674/01	81 51220 6027	08870	682/02
81 43722 0047	15478	674/01	81 51220 6033	08872	682/03
81 43722 0061	21230	674/02	81 51220 6043	08868	682/03
81 43722 0062	15490	674/01	81 51220 6068	08869	682/02
81 44205 6010	08679	657/01	81 51230 0009	10249	667/01
81 44205 6013	08680	657/01	81 51260 6003	07787	667/09
81 44205 6031	17286	657/01	81 51270 6001	06942	682/03
81 45422 0023	18511	653/01	81 51270 6002	12256	667/06
81 45422 0060	18512	653/01	81 52101 6017	07321	667/05
81 45501 0067A	18010	653/01	81 52101 6085	07322	667/04
81 45501 0076	11850	653/02	81 52101 6085	08253	667/07
81 45501 0082	11849	653/02	81 52101 6118	08936	667/04

MAN

RF No.	KTK No.	Page	RF No.	KTK No.	Page
81 52101 6147	10910	667/02	81 95301 6144	16748	644/01
81 52101 6264	12258	667/03	81 95301 6204	19288	644/01
81 52101 6269	17161	667/05	81 95301 6280	13775	644/02
81 52101 6295	17542	667/06	81 95301 6297	13366	652/01
81 52102 0008	10248	667/01	81 95302 0039	09084	672/01
81 52110 6061	12266	667/04	81 95308 5002	12815	652/02
81 52115 6017	07338	667/04	81 96210 0242	15491	610/01
81 52116 6008	10917	667/02	81 96210 0437	15488	677/01
81 52116 6014	07334	667/04	81 96210 0437CPL	15489	677/01
81 52130 6031	11107	667/03	81 96210 0462	15487	677/01
81 52130 6043	12257	667/06	81 96210 0554	16411	673/01
81 52131 6001	07339	667/08	81 96210 0555	19229	673/01
81 52161 6258	08948	667/03	81 96301 0677	21931	623/01
81 52161 6258	08940	667/09	81 96301 0898	21932	623/01
81 52161 6269	08953	667/03	81 96340 0238	08863	682/01
81 52161 9174	10922	667/02	81 96340 0278	08861	682/01
81 52170 6128	10914	651/01	81 96340 0279	08862	682/01
81 52185 6009	10071	667/01	81 96401 0148	08984	650/01
81 52185 6015	10913	667/02	81 96503 0154	09617	655/01
81 52220 6075	08867	682/03	81 96503 0236	08968	645/01
81 52301 6031	07331	667/05	81 96601 0298	19781	655/02
81 52301 6069	08942	667/08	81 96601 0711	22401	605/02
81 52301 6184	12250	667/07	81 97010 6011	19443	647/01
81 52301 6193	12251	667/07	81 97601 0301	07627	625/06
81 52315 6054	12255	667/03	81 97601 0316	07630	625/06
81 52452 6016	20703	635/01	81 97610 0118	06561	658/01
81 54124 6006	15103	629/02	81 97610 0123	06562	658/01
81 54901 0025	06927	629/02	81 97610 0210	15041	658/01
81 61220 6024	08871	682/03	81 97610 0210	06554	658/01
81 62640 6055	21843	680/01	81 99164 3679	07333	667/08
81 62640 6056	21844	680/01	81 99806 2076	13319	682/04
81 62640 6057	21845	680/01	81 99806 2077	13320	682/04
81 62640 6058	21846	680/01	82 52101 6019	08937	667/05
81 62641 6080	19797	679/01	82 52101 6036	11113	667/08
81 62641 6081	19798	679/01	82 52301 6015	12252	667/07
81 74920 6017	20704	635/01	85 30001 9892	16134	642/01
81 90001 0090	08277	625/04	85 41723 6020	16722	678/01
81 90001 0184	06516	656/01	85 41723 6021	19437	678/01
81 90620 0048	07716	656/01	85 50001 4354	07324	667/07
81 90640 0032	07702	656/01	85 50001 4460	13307	667/06
81 90685 0303	07704	654/01	88 11308 0202	07638	627/01
81 90701 0549	06939	650/01	88 15202 0801	11400	630/01
81 90801 0225	07739	659/01	88 52315 6211	10911	667/08
81 93020 0427	10837	632/02	90 80119 5438	07530	625/04
81 93020 0428	10838	632/02	90 81692 9667	07621	625/01
81 93020 0576	07740	659/01	90 91159 0013	07746	668/01
81 93420 0040	12079	649/01			
81 93420 0133	12087	649/01			
81 95301 0013	08883	652/01			
81 95301 0014	08884	652/01			
81 95301 0015	08888	652/01			
81 95301 0016	08887	652/01			
81 95301 0038	08882	644/01			
81 95301 6063	08881	644/01			
81 95301 6064	08880	644/01			

MAN

KTK	RF: No.	Page	KTK	RF: No.	Page
06469	06 56254 2203	604/03	07322	81 52101 6085	667/04
06481	51 03905 0104	630/01	07324	85 50001 4354	667/07
06482	51 98701 0065	600/05	07331	81 52301 6031	667/05
06483	51 08902 0161	600/03	07333	81 99164 3679	667/08
06487	81 32903 0116	650/01	07334	81 52116 6014	667/04
06489	51 05901 0083	604/03	07338	81 52115 6017	667/04
06490	51 01903 0251	600/05	07339	81 52131 6001	667/08
06492	51 08901 0023	600/03	07407	51 04102 0075	615/01
06495	51 54901 0004	629/02	07408		625/05
06498	51 05901 0083	604/03	07409	06 76039 0006	625/05
06508	51 05904 0092	600/05	07411	51 91701 0274	607/01
06511	06 56180 0715	614/01	07527	51 01903 0166	600/06
06512		684/05	07530	90 80119 5438	625/04
06513	06 56190 0706	614/01	07533	51 96501 0295	627/01
06514	06 56190 0709	625/03	07534	81 12905 0055	625/04
06516	81 90001 0184	656/01	07536	51 96501 0264	625/01
06526	81 50610 6051	662/01	07537	51 96501 0265	655/02
06527	81 50610 6052	662/01	07539		682/04
06554	81 97610 0210	658/01	07596	51 04902 0028	600/04
06561	81 97610 0118	658/01	07609	51 04102 0065	615/01
06562	81 97610 0123	658/01	07612	51 04302 0042	615/01
06646	81 50610 6187	661/01	07614	51 04301 0079	606/01
06647	81 50610 6188	661/01	07615	81 12101 6022	625/03
06927	81 54901 0025	629/02	07618	81 11904 0014	625/05
06928	51 54901 0001	629/02	07619	81 12150 6003	625/04
06939	81 90701 0549	650/01	07620	51 12505 0004	625/01
06940	81 32312 0153	650/01	07621	90 81692 9667	625/01
06942	81 51270 6001	682/03	07622	51 12150 7003	625/03
06943	51 96501 0305	605/01	07625	81 12101 0001	625/05
06991	51 03901 0342	600/03	07627	81 97601 0301	625/06
07157		687/01	07628	81 12102 0002	625/06
07158		687/02	07629	81 12104 0003	625/06
07159		687/02	07630	81 97601 0316	625/06
07224	51 90701 0103	607/01	07631	81 12903 0001	625/07
07225	51 90701 0104	607/01	07632	81 12102 0002	625/07
07285		685/01	07633	81 12540 0008	625/06
07286		685/01	07635	51 12501 7019	625/01
07287		685/01	07636	51 96501 0295	625/01
07288		685/01	07638	88 11308 0202	627/01
07289		685/01	07640	51 12501 7115	625/04
07290		685/02	07674	51 06402 0065	616/01
07291		685/02	07676	06 56341 2122	616/01
07292		685/02	07702	81 90640 0032	656/01
07293		685/02	07704	81 90685 0303	654/01
07294		685/03	07705	81 35710 0044	654/01
07295		685/03	07715	81 35710 0045	654/01
07296		685/03	07716	81 90620 0048	656/01
07297		685/03	07737		659/01
07298		685/03	07738	81 50211 0016	659/01
07299		685/04	07739	81 90801 0225	659/01
07300		685/04	07740	81 93020 0576	659/01
07301		685/04	07742	81 51113 0019	668/01
07302		685/04	07743	81 51113 0013	668/01
07321	81 52101 6017	667/05	07744	81 51113 0001	668/01
			07745	81 51113 0002	668/01
			07746	90 91159 0013	668/01

MAN

KTK	RF: No.	Page	KTK	RF: No.	Page
07748	81 51113 0007	668/02	08860		683/02
07749	81 51113 0020	668/02	08861	81 96340 0278	682/01
07750	81 51113 0017	668/02	08862	81 96340 0279	682/01
07764	06 56180 0709	614/01	08863	81 96340 0238	682/01
07765		684/05	08864		682/01
07766	06 71030 2111	684/02	08865		682/01
07767	06 71030 2112	684/02	08866		682/02
07768	06 71030 2121	684/02	08867	81 52220 6075	682/03
07769	06 71030 2114	684/02	08868	81 51220 6043	682/03
07770		684/03	08869	81 51220 6068	682/02
07771		684/03	08870	81 51220 6027	682/02
07772		684/03	08871	81 61220 6024	682/03
07773		684/03	08872	81 51220 6033	682/03
07774		684/03	08873	81 51220 6024	682/02
07775		684/04	08874	81 51220 6025	682/02
07776		684/04	08880	81 95301 6064	644/01
07777		684/04	08881	81 95301 6063	644/01
07778		684/04	08882	81 95301 0038	644/01
07779		684/04	08883	81 95301 0013	652/01
07780		684/05	08884	81 95301 0014	652/01
07781		684/01	08887	81 95301 0016	652/01
07782		684/01	08888	81 95301 0015	652/01
07783		684/01	08906	81 25505 0538	637/01
07784		684/01	08919	51 02130 0013	603/01
07785		684/01	08936	81 52101 6118	667/04
07786		684/02	08937	82 52101 6019	667/05
07787	81 51260 6003	667/09	08940	81 52161 6258	667/09
07929	81 35608 0024	656/01	08942	81 52301 6069	667/08
07931	06 02190 2610	656/01	08946	81 50400 6027	667/01
08120	51 03905 0134	600/03	08947	81 50410 6135	667/02
08121	51 00900 6570	600/03	08948	81 52161 6258	667/03
08218		686/01	08953	81 52161 6269	667/03
08219		686/01	08968	81 96503 0236	645/01
08235		686/01	08984	81 96401 0148	650/01
08251	81 51101 6080	667/05	08992	51 00900 6558	600/04
08253	81 52101 6085	667/07	09010	51 91701 0386	607/01
08277	81 90001 0090	625/04	09059	51 04902 0033	600/01
08366	51 12150 7003	625/03	09084	81 95302 0039	672/01
08375		687/02	09110	06 11222 0218	653/01
08376		687/02	09111		653/02
08377		687/01	09113		653/02
08378		687/01	09114	81 45504 0008	653/03
08464	81 43270 6040	672/01	09115	81 45502 0001	653/01
08511	51 05904 0132	600/05	09123	51 03901 0298	600/04
08546	81 50301 0113	660/01	09615	51 01510 0206	611/01
08547	81 50301 0112	660/01	09616	06 56289 0064	655/01
08665	06 32490 3200	675/01	09617	81 96503 0154	655/01
08679	81 44205 6010	657/01	09694	51 98701 0114	614/01
08620	51 12150 7006	625/03	09835	51 96501 0261	605/01
08680	81 44205 6013	657/01	09840		605/01
08818	81 45503 0026	653/02	09899	06 56341 4254	655/01
08854	04 35160 9704	683/01	10059	51 96501 0262	629/02
08855	04 35160 9706	683/01	10071	81 52185 6009	667/01
08856	04 35160 9207	683/01	10074	81 50410 6018	667/01
08857		683/01	10084	51 12503 0043	625/02
08858		683/01	10117	06 32499 004	675/01
08859	04 35160 9812	683/02	10118	06 32499 0044	675/01
			10119		675/02

MAN













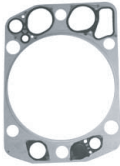

KTK	RF: No.	Page	KTK	RF: No.	Page
10122		625/03	11523	81 25921 6043	632/04
10126	51 12101 7075	625/02	11633	51 10108 0003	605/01
10127	51 12101 7106	625/02	11767	51 04104 0021	613/01
10164	81 39200 6016	670/01	11770	51 04205 0019	613/01
10166	81 39126 6006	670/01	11779	81 06111 0018	621/01
10180	81 35204 0015	656/02	11790	51 93020 1005	613/01
10216	51 02301 7410	602/01	11849	81 45501 0082	653/02
10248	81 52102 0008	667/01	11850	81 45501 0076	653/02
10249	81 51230 0009	667/01	12075	51 96501 0348	600/05
10275	51 54105 6008	629/01	12077		675/02
10276	51 54105 6006	629/03	12078	06 32849 0011	675/02
10297	51 02405 1003	601/01	12079	81 93420 0040	649/01
10400	51 04301 0065	606/01	12087	81 93420 0133	649/01
10401	51 04301 0068	606/01	12091	81 50820 5099	665/01
10833		632/01	12095	51 06520 0068	617/02
10834	81 26225 6003	632/01	12250	81 52301 6184	667/07
10835	81 26212 0011	632/02	12251	81 52301 6193	667/07
10836	81 26212 0012	632/02	12252	82 52301 6015	667/07
10837	81 93020 0427	632/02	12255	81 52315 6054	667/03
10838	81 93020 0428	632/02	12256	81 51270 6002	667/06
10839	81 25921 6040	632/02	12257	81 52130 6043	667/06
10840	81 26203 0002	632/01	12258	81 52101 6264	667/03
10841	81 26203 6019	632/01	12264	81 47101 6008	676/01
10842	81 26203 6007	632/01	12265		642/02
10843		632/03	12266	81 52110 6061	667/04
10844	81 26204 0032	632/03	12585	06 56289 0371	655/01
10845	81 26207 6011	632/03	12586	06 56289 0319	655/01
10847		632/04	12761	81 43220 6206	672/01
10848	81 25601 6014	631/01	12796	81 06110 0027	621/01
10849	51 26101 7148	631/01	12797	81 06110 0025	621/01
10850	51 26101 7201	631/01	12815	81 95308 5002	652/02
10851	51 26101 7092	632/04	13220	51 06601 0102	618/01
10873		675/01	13221	51 06601 0256	618/01
10874	06 32490 3200	675/01	13226	51 05503 6093	604/02
10907		642/01	13255	81 50610 6213	661/01
10910	81 52101 6147	667/02	13256	81 50610 6212	661/02
10911	88 52315 6211	667/08	13257	81 39126 6020	670/01
10913	81 52185 6015	667/02	13307	85 50001 4460	667/06
10914	81 52170 6128	651/01	13319	81 99806 2076	682/04
10916	81 11701 6046	628/01	13320	81 99806 2077	682/04
10917	81 52116 6008	667/02	13321	81 15701 6003	628/01
10919	81 32735 6011	643/01	13324	51 05405 5012	605/01
10920	81 30725 6031	642/01	13366	81 95301 6297	652/01
10921	81 30725 6014	642/02	13536	51 12505 0004	625/02
10922	81 52161 9174	667/02	13570	81 50610 6211	661/02
11009	51 02301 7295	602/01	13571	81 50610 6210	661/02
11017	81 30550 0063	641/01	13716	81 39410 6020	671/01
11021	81 30550 0060	641/01	13721	81 39400 6107	671/01
11024	81 30550 0056	641/01	13775	81 95301 6280	644/02
11034	81 30550 0050	641/01	13865	81 25509 0119	633/01
11036	51 06500 6228	617/02	14220	81 25921 6042	632/03
11038	51 06500 6479	617/03	14224	51 26106 0007	631/01
11107	81 52130 6031	667/03	14228	81 26106 6019	631/01
11113	82 52101 6036	667/08	14250		683/02
11114	81 26485 6016	669/01	14306	51 01510 0094	611/01
11126	51 27421 0009	634/01	14589	81 39410 6019	671/01
11224	81 43270 6080	672/02	14776	81 32638 0006	646/01
11400	88 15202 0801	630/01			
11522	81 25921 6007	632/03			











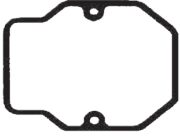

MAN





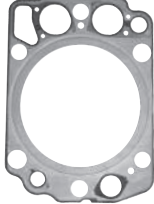





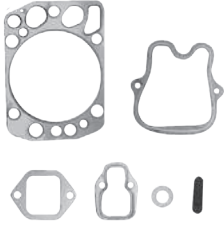

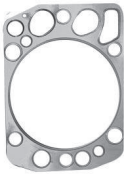
KTK	RF: No.	Page	KTK	RF: No.	Page
14778	81 32638 0005	646/01	16853	81 50301 0283	660/01
15041	81 97610 0210	658/01	16854	81 50301 0224	660/01
15103	81 54124 6006	629/02	17085	81 50610 6132	662/01
15353	51 54100 6046	629/01	17161	81 52101 6269	667/05
15354	51 54114 6073	629/01	17203	81 06102 6208	620/01
15355	51 54114 6081	629/01	17235	81 15210 0084	630/01
15363	81 30300 6002	641/01	17236	81 15210 0086	630/01
15364	81 30300 6004	641/02	17286	81 44205 6031	657/01
15477	81 43722 0021	674/01	17542	81 52101 6295	667/06
15478	81 43722 0047	674/01	17834	81 25101 6290	636/01
15484	81 43722 0019	674/01	17835	81 25101 6289	636/01
15487	81 96210 0462	677/01	17836	81 25101 6449	636/01
15488	81 96210 0437	677/01	17837	81 25101 6448	636/01
15489	81 96210 0437CPL	677/01	17838	81 25101 6453	636/01
15490	81 43722 0062	674/01	17839	81 25101 6452	636/02
15491	81 96210 0242	610/01	17840	81 25320 6101	636/04
15537	81 35710 0067	654/01	17841	81 25320 6112	636/04
15529	06 32499 0153	675/02	17842	81 25320 6111	636/04
15538	81 35710 6009	654/01	17843	81 25225 6545	636/04
15542	81 50803 0009	663/01	17844	81 25225 6544	636/05
15543	81 50803 0040	663/01	17845	81 25229 6060	636/05
15591	51 02401 6141	601/01	17846	81 25229 6059	636/05
15627	51 06500 6546	617/01	18010	81 45501 0067A	653/01
15725	51 00900 6630	600/01	18511	81 45422 0023	653/01
15726	51 03901 0338	600/01	18512	81 45422 0060	653/01
15727	51 03905 0157	600/02	18603	81 43610 6117	667/06
15728	51 03901 0338	600/01	18754	51 04301 0106	606/01
15729	51 08902 0194	600/01	18962	51 54114 6045	629/01
15730	51 03901 0382	600/02	19140	81 25101 6500	636/02
15758		670/01	19141	81 25101 6501	636/02
15793	81 50110 0144	664/01	19142	81 25101 6504	636/02
15794	81 50110 0232	664/01	19143	81 25101 6503	636/02
15820	81 50610 6261	661/01	19161		685/02
15821	81 50610 6262	661/01	19186	81 46610 6722	652/03
15822	51 05601 0121	604/01	19229	81 96210 0555	673/01
15829	06 56279 0362	655/02	19232	51 05805 5425	608/01
15841	51 02400 6044	601/01	19233	51 05805 5609	608/01
16116	81 30725 6065	642/01	19244	81 06102 6218	620/01
16132	81 39410 6023	671/01	19288	81 95301 6204	644/01
16134	85 30001 9892	642/01	19377	81 50820 5085	665/01
16139	51 06500 7049	617/01	19437	85 41723 6021	678/01
16181	81 30725 6062	642/01	19443	81 97010 6011	647/01
16222	51 06500 7066	617/01	19446	81 32620 0045	647/01
16223	51 06500 6547	617/01	19447	81 32620 0039	647/01
16227	51 03905 0161	600/02	19451	81 32655 6129	648/01
16364	81 50820 6059	665/01	19454	81 32655 6182	643/01
16365	81 50820 6046	665/01	19455	81 32655 6181	643/01
16383	51 95800 7435	619/01	19498	51 06500 6676	617/01
16401	51 95800 7431	619/01	19713	81 30715 6152	642/02
16403	81 06102 6209	620/01	19718	81 30715 6135	642/02
16404	81 06102 6203	620/01	19756		666/01
16411	81 96210 0554	673/01	19758	51 27120 7038	609/01
16445	81 25509 0144	633/01	19760	81 27421 0237	624/01
16455	51 06601 0275	618/01	19761	51 27421 0216	624/01
16722	85 41723 6020	678/01	19781	81 96601 0298	655/02
16748	81 95301 6144	644/01			













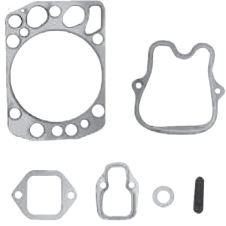

MAN

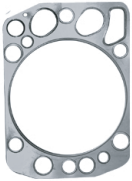





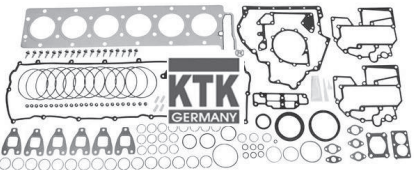







KTK	RF: No.	Page	KTK	RF: No.	Page
19797	81 62641 6080	679/01	22164	81 32620 0044	647/02
19798	81 62641 6081	679/01	22401	81 96601 0711	605/02
19816	81 27120 0016	609/01	22402	51 96601 0575	617/03
19821	36 27120 6005	666/01	22405	51 08901 0209	612/01
19827	81 25505 0930	637/01	22406	51 08901 0182	612/01
19909	51 06903 0061	617/02	22407	51 06904 0039	616/01
19910	51 06904 0042	617/02	22408	51 06903 0030	617/03
19911	51 06901 0192	617/02	22410	51 00900 6652	600/04
19924	81 06130 0083	622/01	22412	51 00900 6680	600/04
19980	81 43230 6061	672/01	22413	51 05904 0198	600/06
20013	81 25260 6101	636/03	22414	51 08901 0155	600/02
20014	81 25225 6524	636/05	22415	51 03905 0187	600/02
20018	81 30725 6084	642/02	22563	81 41722 6013	681/01
20023	81 25225 6523	636/05	22649	81 41722 6012	682/02
20024	81 25229 6052	636/06	22650	85 41722 6011	682/02
20025	81 25320 6090	636/03	22651	85 41722 6017	682/03
20026	81 25320 6089	636/03	22666	81 27421 0232	624/01
20027	81 25101 6522	636/03	22727	81 50803 0044	663/01
20028	81 25101 6521	636/03	22795	85 41722 6015	681/02
20029	81 25260 6099	636/04	22796	85 41722 6014	681/02
20306	51 12101 7139	626/01	22797	81 43701 6600	681/01
20307	51 12101 7149	626/01	22798	81 41722 6052	681/01
20308	51 15101 7148	626/01	22799	81 41722 6051	681/01
20423	81 43220 6108	672/02	22800	81 41722 6057	681/01
20493	81 43270 6119	672/02	22859	51 06500 6675	617/03
20678	81 52151 6095	667/09	22860	51 02401 6243	601/01
20687	81 43610 6061	635/01	23041	81 50610 6263	661/02
20688	81 25937 0015	635/01	23043	81 32620 0049	647/01
20703	81 52452 6016	635/01	23044	81 32620 0095	647/01
20704	81 74920 6017	635/01	23141	81 25101 6451	636/06
20818	81 30715 6132	643/01	23142	81 25101 6450	636/06
20897		687/01	23353	51 06330 5033	617/03
20898		687/01	23437	81 50820 5023	665/01
20937	81 06130 0197	622/01	23472	81 25921 6058	632/04
21099	81 50803 0041	663/01	23505	81 25311 0006	637/02
21229	81 43270 6105	672/01	23506	81 25311 0023	637/02
21230	81 43722 0061	674/02	23731	51 01901 0128	617/04
21352	51 02301 7440	602/01	23732	51 08901 0170	630/01
21355	51 02301 5210	602/01	23763	81 50410 6540	667/09
21356	51 02301 5210	602/01			
21387	51 12150 0001	625/02			
21603	81 46611 6197	652/03			
21604	81 46711 6858	652/03			
21663	81 47101 6162	676/01			
21839	81 26401 6119	638/01			
21840	81 26401 6132	638/01			
21841	81 26411 6111	638/01			
21842	81 28601 6143	640/01			
21843	81 62640 6055	680/01			
21844	81 62640 6056	680/01			
21845	81 62640 6057	680/01			
21846	81 62640 6058	680/01			
21931	81 96301 0677	623/01			
21932	81 96301 0898	623/01			

KTK No.	RF No.	Bezeichnung Description Désignation	Erläuterungen Remarks Remarques
<p>15725</p>  <p>4 057822 157258</p>  	<p>51 00900 6630</p>	<p>Dichtsatz Gasket kit / Kit de joints</p>	<p>TGA - φ144 F2000/E2000 D2876/2866</p>
<p>15726</p>  <p>4 057822 157265</p>  	<p>51 03901 0338</p>	<p>Zylinderkopfdichtung Cylinder head gasket Joint de culasse</p>	
<p>15728</p>  <p>4 057822 157289</p>  	<p>51 08901 0152</p>	<p>Zylinderkopfdichtung Cylinder head gasket Joint de culasse</p>	
<p>15729</p>  <p>4 057822 157296</p>  	<p>51 08902 0194</p>	<p>Dichtung Gasket intake / Joint</p>	
<p>09059</p>  <p>4 057822 090593</p>  	<p>51 04902 0033</p>	<p>Ventilschaftdichtung Valve seal Joint de guide de soupape</p>	



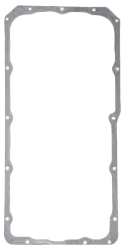









KTK No.	RF No.	Bezeichnung Description Désignation	Erläuterungen Remarks Remarques
15727	 4 057822 157272		
		51 03905 0157	Dichtung Gasket valve cover / Joint TGA F2000/E2000
16227	 4 057822 162276		
		51 03905 0161 51 03905 0176 51 03905 0179 51 03905 0180 51 03905 0190	Dichtung Gasket valve cover / Joint TGA F2000/E2000
22415	 4 057822 224158		
		51 03905 0187	Dichtung Gasket valve cover / Joint D2876
15730	 4 057822 157302		
		51 03901 0382	Zylinderkopfdichtung Cylinder head gasket Joint de culasse TGA - ϕ 129 F2000/E2000 D2866
22414	 4 057822 224141		
		51 08901 0155	Gasket, exhaust D2876















KTK No.	RF No.	Bezeichnung Description Désignation	Erläuterungen Remarks Remarques
<p data-bbox="279 197 359 228">08121</p>  <p data-bbox="520 259 687 282">4 057822 081218</p>  	<p data-bbox="751 371 932 403">51 00900 6570</p>	<p data-bbox="995 371 1262 443">Dichtsatz Gasket kit / Kit de joints</p>	<p data-bbox="1299 371 1453 481">D2566, 2556 125mm SD/SG/SL/SR</p>
<p data-bbox="279 577 359 609">06991</p>  <p data-bbox="520 640 687 663">4 057822 069919</p>  	<p data-bbox="751 707 932 739">51 03901 0342</p>	<p data-bbox="995 707 1230 817">Zylinderkopfdichtung Cylinder head gasket Joint de culasse</p>	<p data-bbox="1299 707 1453 739">D2566, 2556</p>
<p data-bbox="279 947 359 978">08120</p>  <p data-bbox="520 1010 687 1032">4 057822 081201</p>  	<p data-bbox="751 1099 932 1131">51 03905 0134</p>	<p data-bbox="995 1099 1150 1171">Dichtung Gasket / Joint</p>	<p data-bbox="1299 1099 1453 1131">D2566, 2556</p>
<p data-bbox="279 1339 359 1370">06483</p>  <p data-bbox="520 1402 687 1424">4 057822 064839</p>  	<p data-bbox="751 1503 932 1534">51 08902 0161</p>	<p data-bbox="995 1503 1225 1574">Dichtung Gasket intake / Joint</p>	
<p data-bbox="279 1731 359 1762">06492</p>  <p data-bbox="520 1794 687 1816">4 057822 064921</p>  	<p data-bbox="751 1883 932 1915">51 08901 0023</p>	<p data-bbox="995 1883 1241 1955">Dichtung Gasket exhaust / Joint</p>	

KTK No.	RF No.	Bezeichnung Description Désignation	Erläuterungen Remarks Remarques
07596			
 4 057822 075965			
 	51 04902 0028	Ventilschaftdichtung Valve seal Joint de guide de soupape	F2000 D2866/E2866
08992			
 4 057822 089924			
 	51 00900 6558	Dichtsatz Head gasket kit Jeu de joints	D2840, 2842 D2866 128mm F2000/F90/M90
09123			
 4 057822 091231			
 	51 03901 0298	Dichtsatz Head gasket Jeu de joints	D2840, 2842 D2866 128mm
22410			
 4 057822 224103			
 	51 00900 6652	Full gasket kit	D2876
22412			
 4 057822 224127			
 	51 00900 6680	Full gasket kit	D2066 121mm

KTK No.	RF No.	Bezeichnung Description Désignation	Erläuterungen Remarks Remarques
08511	 4 057822 085117		
 	51 05904 0132	Dichtung, Ölwanne Gasket , oil pan Joing, carter d'huile	TGA F2000/F90/E2000 D2556/2566 2866/2876
06490	 4 057822 064907		
 	51 01903 0251	Dichtsatz Gasket, engine Joint	D2866
12075	 4 057822 120757		
 	51 96501 0348	Scheibe 6mm Washer, fuel return pipe Rondelle	F90/M90
06508	 4 057822 065089		
 	51 05904 0092	Dichtung Gasket / Joint	
06482	 4 057822 064822		
 	51 98701 0065	Scheibe Washer Rondelle	

KTK No.	RF No.	Bezeichnung Description Désignation	Erläuterungen Remarks Remarques
07527	 4 057822 075279		
		51 01903 0166	Dichtung Gasket Joint
22413	 4 057822 224134		
		51 05904 0198	Dichtung Gasket Joint

KTK No.	RF No.	Bezeichnung Description Désignation	Erläuterungen Remarks Remarques	
15591	 4 057822 155919			
		51 02401 6141	Pleuelstange Connecting rod Tige de bielle	D-2555/56/65/66
15841	 4 057822 158415			
		51 02400 6044	Pleuelstange Connecting rod Tige de bielle	D2866 TGA
10297	 4 057822 102975			
		51 02405 1003	Pleuelbuchse Connecting rod bush Douille de bielle	
22860	 4 057822 228603			
		51 02401 6243 51 02400 6011 51 02400 6049	Pleuelstange Connecting rod Tige de bielle	D2876 TGA

KTK No.	RF No.	Bezeichnung Description Désignation	Erläuterungen Remarks Remarques	
11009	 4 057822 110093			
		51 02301 7295	Schwungrad Fly wheel Volant moteur	380mm
10216	 4 057822 102166			
		51 02301 7410	Schwungrad Fly wheel Volant moteur	400mm Teeth : 160
21352	 4 057822 213527			
		51 02301 7440 51 02301 3228 51 02301 5034	Schwungrad Fly wheel Volant moteur	430mm D 2866
21355	 4 057822 213558			
		51 02301 5210 51 02301 5259	Schwungrad Fly wheel Volant moteur	D 2066 430mm
21356	 4 057822 213565			
		51 02301 5209 51 02301 5258	Schwungrad Fly wheel Volant moteur	D 2066

KTK No.	RF No.	Bezeichnung Description Désignation	Erläuterungen Remarks Remarques
---------	--------	---	---------------------------------------

08919



4 057822 089191



51 02130 0013

Laufring
Racer
Chemin de roulement

115x120x21
F2000/F90



KTK No.	RF No.	Bezeichnung Description Désignation	Erläuterungen Remarks Remarques
15822			
 4 057822 158224			
	51 05601 0121	Ölkühler Oil cooler Refroidisseur d'huile	D2866
			

KTK No.

13226



4 057822 132262

RF No.









51 05503 6093





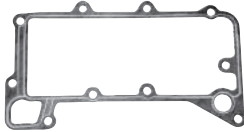









**Bezeichnung
Description
Désignation**







Ölkühlergehäuse
Oil cooler housing
Carter de refroidisseur d'huile













**Erläuterungen
Remarks
Remarques**















KTK No.	RF No.	Bezeichnung Description Désignation	Erläuterungen Remarks Remarques
06469	 4 057822 064693		
		06 56254 2203	Dichtung Gasket / Joint
06489	 4 057822 064891		
		51 05901 0083	Dichtung Gasket / Joint
06498	 4 057822 064983		
		51 05901 0083	Dichtung Gasket / Joint



KTK No.	RF No.	Bezeichnung Description Désignation	Erläuterungen Remarks Remarques
06943	 4 057822 069438		
		51 96501 0305	O Ring, oil breather O-ring / Joint torique
09835	 4 057822 098353		
		51 96501 0261	O Ring, thermostat O-ring / Joint torique
09840	 4 057822 098407		
		51 08902 0128	Dichtung Gasket / Joint
11633	 4 057822 116330		
		51 10108 0003	Hülse, Düsenhalter Sleeve, Nozzle holder Douille, support gicleur
13324	 4 057822 133245		
		51 05405 5012	Überströmventil Overflow valve Valve de sécurité

KTK No.	RF No.	Bezeichnung Description Désignation	Erläuterungen Remarks Remarques
22401	 4 057822 224011		
		81 96601 0711	Gasket, differential
22739	 4 057822 227395		
			Nozzle holder
			TGA

KTK No.		RF No.	Bezeichnung Description Désignation	Erläuterungen Remarks Remarques
10400	 4 057822 104009			
		51 04301 0065	VantilstÖssel Valve tappet Pousoir soupape	F90/M90
10401	 4 057822 104016			
		51 04301 0068	VantilstÖssel Valve tappet Pousoir soupape	F90
18754	 4 057822 187545			
		51 04301 0106	Vantilst ssel Valve tappet Pousoir soupape	F2000/TGA
07614	 4 057822 076146			
		51 04301 0079	VentilstÖbel Valve tappet Pousoir de soupape	

KTK No.	RF No.	Bezeichnung Description Désignation	Erläuterungen Remarks Remarques
07224	 4 057822 072247		
 	51 90701 0103	Ausgleichscheibe Shim Inner Cale	
07225	 4 057822 072254		
 	51 90701 0104	Ausgleichscheibe Shim Cale	
07411	 4 057822 074111		
 	51 91701 0274	Hülse Sleeve Douille	
09010	 4 057822 090104		
 	51 91701 0386	Klemmstück Spacer / Agrafe	F90

KTK No.	RF No.	Bezeichnung Description Désignation	Erläuterungen Remarks Remarques
19232	 4 057822 192327		
 	51 05805 5425	Ölmesstab Oil dipstick Jauge de niveau d'huile	D 2866 1750 mm
19233	 4 057822 192334		
 	51 05805 5609	Ölmesstab Oil dipstick Jauge de niveau d'huile	D 2876 1700 mm

KTK No.	RF No.	Bezeichnung Description Désignation	Erläuterungen Remarks Remarques
19758	 4 057822 197582	51 27120 7038 51 27120 7037 51 27120 7035 51 27120 0016	Drehzahlsensor Rotation sensor, Crankshaft Capteur de régime
19816	 4 057822 198169	81 27120 0016 84 27120 0027	Impulsgeber Impulse sensor, RPM Capteur d'impulsions



KTK No.	RF No.	Bezeichnung Description Désignation	Erläuterungen Remarks Remarques
---------	--------	---	---------------------------------------

15491

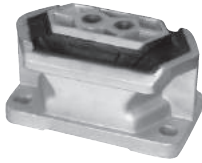



81 96210 0242
81 96210 0227









Gummilager
Mounting, engine
Silentbloc

M16x1.5

KTK No.	RF No.	Bezeichnung Description Désignation	Erläuterungen Remarks Remarques	
09615	 4 057822 096151			
		51 01510 0206	Wellendichtring Oil seal, crankshaft Bague d'etanchéité	120x140x13/12 F2000/F90 M90
14306	 4 057822 143060			
		51 01510 0094	Wellendichtring Sealring Bague d'etanchéité	115x140x13

KTK No.	RF No.	Bezeichnung Description Désignation	Erläuterungen Remarks Remarques
22405	 4 057822 224059	51 08901 0209 Gasket, Turbo	TGA 2066
22406	 4 057822 224066	51 08901 0182 51 08901 0097 51 08901 0151 Gasket, Turbo	TGA



KTK No.	RF No.	Bezeichnung Description Désignation	Erläuterungen Remarks Remarques
11790	 4 057822 117900		
		51 93020 1005	Buchse Bush Bague
11770	 4 057822 117702		
		51 04205 0019	Einstellschraube, Kipphebel Adjusting screw, rocker arm Vis de réglage
11767	 4 057822 117672		
		51 04104 0021	Kegelstück Valve lock, Middle lock type Clavette

KTK No.	RF No.	Bezeichnung Description Désignation	Erläuterungen Remarks Remarques
07764	 4 057822 077648		
		06 56180 0709	Kupferdichtring Copper washer Rondelle de cuivre
	8x11.5x1		
06511	 4 057822 065119		
		06 56180 0715	Kupferdichtring Copper washer Rondelle de cuivre
	10x14x1.5		
06513	 4 057822 065133		
		06 56190 0706	Kupferdichtring Copper washer Rondelle de cuivre
	14x20x1.5		
06514			
		06 56190 0709	Kupferdichtring Copper washer Rondelle de cuivre
	16x22x1.5		
09694	 4 057822 096946		
		51 98701 0114	Kupferdichtring Copper washer Rondelle de cuivre

KTK No.	RF No.	Bezeichnung Description Désignation	Erläuterungen Remarks Remarques
---------	--------	---	---------------------------------------

07407



51 04102 0075

Ventilfeder
Valve spring
Ressort de soupape



07609



51 04102 0065

Ventilfeder
Valve spring
Ressort de soupape



07612



51 04302 0042

Stößelstange, Einl. und Ausl.
Push rod intake and exhaust
Tige de culbuteur



KTK No.	RF No.	Bezeichnung Description Désignation	Erläuterungen Remarks Remarques
---------	--------	---	---------------------------------------

07674



4 057822 076740



51 06402 0065

Thermostat

71 C



07676



4 057822 076764



06 56341 2122

O - Ring
O-ring / Joint torique



22407

















4 057822 224073



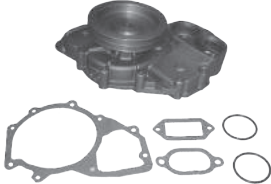







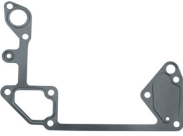

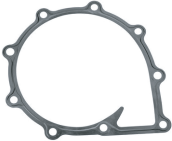





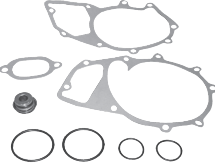

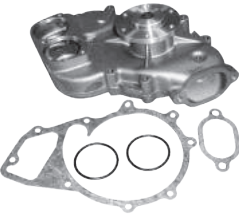



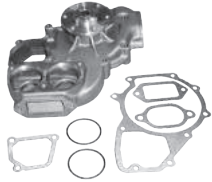



51 06904 0039

Dichtung, Thermostatgehäuse
Gasket, Thermostat housing
Joint, carter de thermostat



KTK No.	RF No.	Bezeichnung Description Désignation	Erläuterungen Remarks Remarques
15627			
	 4 057822 156275 	51 06500 6546 Wasserpumpe Water pump Pompe á eau	F 2000
16139			
	 4 057822 161392 	51 06500 7049 51 06500 9049 51 06500 6637 51 03203 0339 Wasserpumpe Water pump Pompe á eau	TGA/TGS/TGX
16222			
	 4 057822 162221 	51 06500 7066 Wasserpumpe Water pump Pompe á eau	TGA
16223			
	 4 057822 162238 	51 06500 6547 Wasserpumpe Water pump Pompe á eau	F 2000 F 90 / M 90
19498			
	 4 057822 194987 	51 06500 6676 51 06500 6646 51 06500 6695 51 06500 7050 51 06500 9050 51 06500 9646 51 06500 9676 Wasserpumpe Water pump Pompe á eau	BUS

KTK No.	RF No.	Bezeichnung Description Désignation	Erläuterungen Remarks Remarques
19909			
 4 057822 199098  	51 06903 0061	Dichtung Gasket, water pump housing Joint	TGA
19911			
 4 057822 199111  	51 06901 0192	Dichtung Gasket, water pump Joint	
19910			
 4 057822 199104  	51 06904 0042	Dichtung Gasket, thermostat housing Joint	
12095			
 4 057822 120955  	51 06520 0068	Reparatursatz Repair kit Kit de réparation	
11036			
 4 057822 110369  	51 06500 6228	Wasserpumpe Water pump Pompe à eau	

KTK No.	RF No.	Bezeichnung Description Désignation	Erläuterungen Remarks Remarques
11038			
	 4 057822 110383	51 06500 6479 Wasserpumpe Water pump Pompe á eau	
22402			
	 4 057822 224028	51 96601 0575 51 96601 0543 Dichtung Gasket, water pipe Joint	
22408			
	 4 057822 224080	51 06903 0030 Dichtung, Kühlmittelrohr Gasket, coolant pipe Joint	
22859			
	 4 057822 228590	51 06500 6675 51 06500 6694 51 06500 9642 Wasserpumpe Water pump Pompe á eau	
23353			
	 4 057822 233532	51 06330 5033 51 06330 5040 51 06330 5043 Wasserpumpengehäuse Water pump housing Carter de pompe á eau	

KTK No.	RF No.	Bezeichnung Description Désignation	Erläuterungen Remarks Remarques
---------	--------	---	---------------------------------------





23731





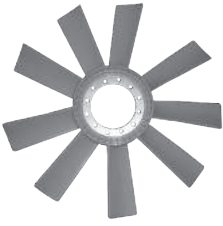





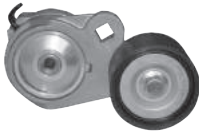





51 01901 0128
 51 01901 0126
 51 01901 0129
 51 01901 0131









Dichtung
 Gasket, water pump
 Joint

TGA



KTK No.	RF No.	Bezeichnung Description Désignation	Erläuterungen Remarks Remarques	
13220	 4 057822 132200	 51 06601 0102	Lufterrad Fan Ventilateur	620x125mm
13221	 4 057822 132217	 51 06601 0256	Lufterrad Fan Ventilateur	705x127mm
16455	 4 057822 164553	 51 06601 0275	Lufterrad Fan Ventilateur	TGA 750mm

KTK No.	RF No.	Bezeichnung Description Désignation	Erläuterungen Remarks Remarques
16383	 4 057822 163839	 51 95800 7435 Riemenspanner 51 95800 7386 Belt tensioner 51 95800 7418 Tendeur de courroie 51 95800 7425	NG / NL
16401	 4 057822 164010	 51 95800 7431 Spannrolle Tension roller galet tendeur	TGA









KTK No.		RF No.	Bezeichnung Description Désignation	Erläuterungen Remarks Remarques
16403	 4 057822 164034			
		81 06102 6209 81 06102 6110 81 06102 6112 81 06102 6205	Ausdehnungsgefäß Expansion tank Vase d'expansion	F2000
16404	 4 057822 164041			
		81 06102 6203 81 06102 6100	Ausdehnungsgefäß Expansion tank Vase d'expansion	M2000 / F90
17203	 4 057822 172039			
		81 06102 6208	Ausdehnungsgefäß Expansion tank Vase d'expansion	F2000
19244	 4 057822 192440			
		81 06102 6218 81 06102 6202	Ausdehnungsgefäß Expansion tank Vase d'expansion	TGA F2000/90















KTK No.	RF No.	Bezeichnung Description Désignation	Erläuterungen Remarks Remarques
12796	 4 057822 127961		
		81 06110 0027	Kühlerverschluss Radiator cap Bouchon de radiateur
12797	 4 057822 127978		
		81 06110 0025	Kühlerverschluss Radiator cap Bouchon de radiateur
11779	 4 057822 117795		
		81 06111 0018 81 06111 0017	Kühlerverschluss Radiator cap Bouchon de radiateur















KTK No.	RF No.	Bezeichnung Description Désignation	Erläuterungen Remarks Remarques
19924			
 4 057822 19924 1			
 	81 06130 0083 81 06130 0073 81 06130 0182 81 06130 0181 81 06130 0129 81 06130 0128	Ladeluftkühler Intercooler Radiateur à air	81 06130 0102 81 06130 0101 81 06130 0082 81 06130 0076
20937			
 4 057822 20937 7			
 	81 06130 0197 81 06130 0179 81 06130 0215 81 06130 0231	Ladeluftkühler Intercooler Radiateur à air	TGA















KTK No.	RF No.	Bezeichnung Description Désignation	Erläuterungen Remarks Remarques
21931	 4 057822 219314	81 96301 0677	Kühlerschlauch Radiator hose Durite de radiateur
21932	 4 057822 219321	81 96301 0898 81 96301 0971 82 96301 0006	TGA



























KTK No.		RF No.	Bezeichnung Description Désignation	Erläuterungen Remarks Remarques
19760	 4 057822 197605			
		81 27421 0237 81 27421 0242 81 27421 0253 81 27421 0264	Temperature sensor	
19761	 4 057822 197612			
		51 27421 0216 51 27421 0179 51 27421 0198	Ladedrucksensor Pressure sensor Capteur de pression de suralimentation	
22666	 4 057822 226664			
		81 27421 0232	Niveausensor Level sensor, coolant Capteur de niveau	



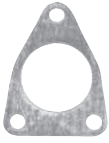

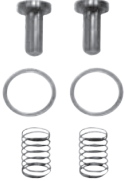









KTK No.	RF No.	Bezeichnung Description Désignation	Erläuterungen Remarks Remarques
07620			
 4 057822 076207			
 	51 12505 0004	überströmventil Overflow valve Clapet anti-retour	D0826
07621			
 4 057822 076214			
 	90 81692 9667	überströmventil Overflow valve Clapet anti-retour	
07636			
 4 057822 076368			
 	51 96501 0295	Dichtring Seal ring Bague d'etanchéité	8mm
07536			
 4 057822 075361			
 	51 96501 0264 51 96501 0322	O-Ring O-ring / Joint torique	D2566/2866
07635			
 4 057822 076351			
 	51 12501 7019	Kraftstofffilter Fuel filter Filtre carburant	D2865/2866

KTK No.	RF No.	Bezeichnung Description Désignation	Erläuterungen Remarks Remarques
10084			
	 4 057822 10084 1 	51 12503 0043 Reparaturatz Repair kit Kit de réparation	TGA
10126			
	 4 057822 10126 8 	51 12101 7075 51 12101 7107 Handpumpe Hand pump Pompe à main	φ12mm
10127			
	 4 057822 10127 5 	51 12101 7106 51 12101 7081 Handpumpe Hand pump Pompe à main	φ14mm F90
13536			
	 4 057822 13536 2 	51 12505 0004 Ventil Return valve Soupape	
21387			
	 4 057822 21387 9 	51 12150 0001 51 12150 0000 51 12150 0002 Handpumpe Prefilter Pompe à main	

KTK No.	RF No.	Bezeichnung Description Désignation	Erläuterungen Remarks Remarques
07622	 4 057822 076221		
 	51 12150 7003	Handpumpe Hand primer Pompe á main	TGA F2000/F90 G90/L2000 M2000/M90
08620	 4 057822 086206		
 	51 12150 7006	Handpumpe Hand primer Pompe á main	TGA/TGX/TGM F2000/L2000 M2000/M90
07615	 4 057822 076153		
 	81 12101 6022	Förderpumpe Feed pump Pompe d'alimentation	
10122	 4 057822 101220		
 	51 12101 7067	Handpumpe Hand pump Pompe á main	
08366	 4 057822 083663		
 	51 12150 7003	Handpumpe Hand pump, aluminium Pompe á main	

KTK No.	RF No.	Bezeichnung Description Désignation	Erläuterungen Remarks Remarques
07619	 4 057822 076191		
		81 12150 6003	Handpumpe Hand pump, steel Pompe á main
07530	 4 057822 075309		
		90 80119 5438	Dichtung Gasket / Joint
07534	 4 057822 075347		
		81 12905 0055	Dichtring Sealring Bague d'etanchéité
08277	 4 057822 082772		
		81 90001 0090	Schraube Screw, filter Vis
07640	 4 057822 076405		
		51 12501 7115	Kraftstofffilter Fuel filter Filtre carburant

KTK No.	RF No.	Bezeichnung Description Désignation	Erläuterungen Remarks Remarques
07409	 4 057822 074098	 06 76039 0006	Reparatursatz Repair kit Kit de réparation
07618	 4 057822 076184	 81 11904 0014	Dichtung Gasket Joint
07408	 4 057822 074081	 2447 010 011	Reparatursatz, Förderpumpe Repair kit, feed pump Kit de réparation, pompe d'alimentation
07625	 4 057822 076252	 81 12101 0001	Ventil / Valve / Soupape Vis
06514	 4 057822 065140	 06 56190 0709	Scheibe Washer / Rondelle

KTK No.	RF No.	Bezeichnung Description Désignation	Erläuterungen Remarks Remarques
07627	 4 057822 076276		
		81 97601 0301 Feder / Spring / Ressort	
07633	 4 057822 076337		
		81 12540 0008 Reparatursatz Bracket, repair kit Kit de réparation	
07628	 4 057822 076283		
		81 12102 0002 Reparatursatz 81 12102 0003 Repair kit Kit de réparation	
07629	 4 057822 076290		
		81 12104 0003 Kraftstofffilter Fuel filter Filtre carburant	
07630	 4 057822 076306		
		81 97601 0316 Feder Spring Ressort	

KTK No.	RF No.	Bezeichnung Description Désignation	Erläuterungen Remarks Remarques
---------	--------	---	---------------------------------------

07631



81 12903 0001

Scheibe
Washer
Rondelle











07632



81 12102 0002

Schauglas
Inspection bowl
Verre de filtre



KTK No.	RF No.	Bezeichnung Description Désignation	Erläuterungen Remarks Remarques
20306	 4 057822 203061		
		51 12101 7139	Kraftstoffpumpe Fuel pump Pompe à carburant
20307	 4 057822 203078		
		51 12101 7149	Kraftstoffpumpe Fuel pump Pompe à carburant
20308	 4 057822 203085		
		51 15101 7148	Kraftstoffpumpe Fuel pump Pompe à carburant

KTK No.	RF No.	Bezeichnung Description Désignation	Erläuterungen Remarks Remarques
---------	--------	---	---------------------------------------

07533



51 96501 0295

Dichtring
Seal ring
Bague d'etanchéité

Old version
12mm









07638















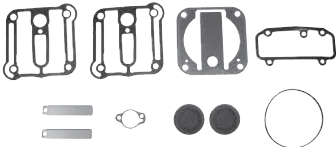

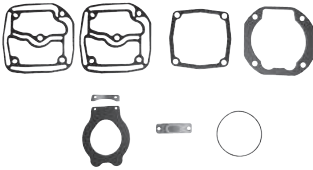

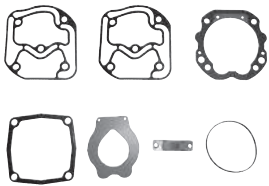

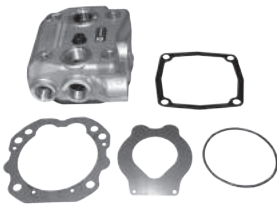



88 11308 0202

Scheibe, Einspritzkupplung
Disc, injection coupling
Disque, injection

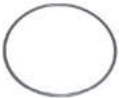

KTK No.	RF No.	Bezeichnung Description Désignation	Erläuterungen Remarks Remarques	
13321	 4 057822 133214	81 15701 6003	Zylinder Cylinder / Cylindre	
 	81 15701 6003	Zylinder Cylinder / Cylindre		
10916	 4 057822 109165	81 11701 6046	Zylinder Cylinder Cylindre	8mm
 	81 11701 6046	Zylinder Cylinder Cylindre	8mm	

KTK No.	RF No.	Bezeichnung Description Désignation	Erläuterungen Remarks Remarques
10275			
 <p>4 057822 102753</p>			
 	51 54105 6008	Kolben-Laufbuchsensatz Piston with liner Kit piston et chemise	Water type 90mm L2000/M2000/90
15353			
 <p>4 057822 153533</p>			
 	51 54100 6046	Reparatursatz Repair kit Kit de réparation	TGA 41.430 460 / 400
15354			
 <p>4 057822 153540</p>			
 	51 54114 6073 51 54114 6066	Reparatursatz Repair kit Kit de réparation	D/E/G/2866
15355			
 <p>4 057822 153557</p>			
 	51 54114 6081	Reparatursatz Repair kit Kit de réparation	TGA
18962			
 <p>4 057822 189624</p>			
 	51 54114 6045 51 54114 6024	Zylinderkopf, Kompressor Head, compressor Culasse, compresseur	F2000

KTK No.	RF No.	Bezeichnung Description Désignation	Erläuterungen Remarks Remarques
15103			
	 <p>4 057822 151034</p>	<p>81 54124 6006</p> <p>Reparatursatz Repair kit water Kit de réparation</p>	<p>For 90mm cooled liner</p>
<p>06495</p> 	 <p>4 057822 064952</p>	<p>51 54901 0004</p> <p>Dichtung Gasket / Joint</p>	
<p>06927</p> 	 <p>4 057822 069278</p>	<p>81 54901 0025</p> <p>Dichtung Gasket / Joint</p>	
<p>06928</p> 	 <p>4 057822 069285</p>	<p>51 54901 0001 51 54901 0027</p> <p>Dichtung Gasket / Joint</p>	
<p>10059</p> 	 <p>4 057822 100599</p>	<p>51 96501 0262</p> <p>O-Ring O-ring / Joint torique</p>	

KTK No.

10276



4 057822 102760

RF No.

**Bezeichnung
Description
Désignation**

**Erläuterungen
Remarks
Remarques**

























51 54105 6006
51 54119 6003







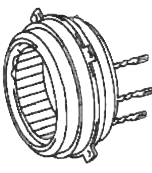







Kolben-Laufbuchsensatz
Piston with liner
Kit piston et chemise







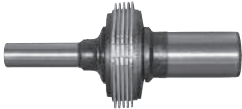



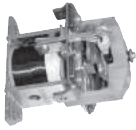

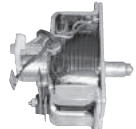
Air type 90mm











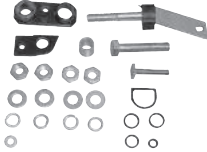



















KTK No.	RF No.	Bezeichnung Description Désignation	Erläuterungen Remarks Remarques
17235	 4 057822 172350		
		81 15210 0084	Flexibles Rohr Flexible pipe
TGA / F2000 376x430			
17236	 4 057822 172367		
		81 15210 0086	Flexibles Rohr Flexible pipe
TGA 420x490			
11400	 4 057822 114008		
		88 15202 0801	Schelle Clamp Bride
4"			
06481	 4 057822 064815		
		51 03905 0104	Dichtung Gasket / Joint
23732	 4 057822 237325		
		51 08901 0170	Dichtung Gasket / Joint
TGA			







KTK No.	RF No.	Bezeichnung Description Désignation	Erläuterungen Remarks Remarques
10848	 4 057822 108489	 81 25601 6014 Regler 81 25601 6016 Regulator 81 25601 6024 Régulateur	F2000/M2000
10849	 4 057822 108496	 51 26101 7148 Generator Alternator Générateur	
10850	 4 057822 108502	 51 26101 7201 Generator Alternator Générateur	E/F/L/M-2000 F90/G90
14224	 4 057822 142247	 51 26106 0007 Generator Alternator Générateur	
14228	 4 057822 142285	 81 26106 6019 Generator Starer Générateur	

KTK No.		RF No.	Bezeichnung Description Désignation	Erläuterungen Remarks Remarques
10840	 4 057822 108403			
		81 26203 0002 81 26203 6018	Anker Armature Induit	24V, 5.4KW Small
10841	 4 057822 108410			
		81 26203 6019	Anker Armature Induit	
10842	 4 057822 108427			
		81 26203 6007	Anker Armature Induit	Big
10833	 4 057822 108335			
			Reparatursatz Repair kit Kit de réparation	1987 010 000
10834	 4 057822 108342			
		81 26225 6003	Lamellenkupplung Starter clutch Embrayage multi-disque	

KTK No.	RF No.	Bezeichnung Description Désignation	Erläuterungen Remarks Remarques
10835	 4 057822 108359		
		81 26212 0011	Magnetschalter Solenoid switch Electrovalve
10836	 4 057822 108366		
		81 26212 0012	Magnetschalter Solenoid switch Electrovalve
10837	 4 057822 108373		
		81 93020 0427	Büchse Bushing / Bague
10838	 4 057822 108380		
		81 93020 0428	Büchse Bushing / Bague
10839	 4 057822 108397		
		81 25921 6040	Kohlebürstensatz Carbon brush set Balai d'alternateur

KTK No.	RF No.	Bezeichnung Description Désignation	Erläuterungen Remarks Remarques
10843	 4 057822 108342	  81 26204 0032 Feldwicklung Filed winding Bobine inductrice	
10844	 4 057822 108441	  81 26207 6011 Pinsel Inhaber Brush holder Support de balai	
10845	 4 057822 108458	  81 25921 6042 Kohlebürstensatz Carbon brush set Balai d'alternateur	
14220	 4 057822 142209	  81 25921 6007 Kohlebürstensatz Carbon brush set Balai d'alternateur	
11522	 4 057822 115227	  81 25921 6007 Kohlebürstensatz Carbon brush set Balai d'alternateur	

KTK No.		RF No.	Bezeichnung Description Désignation	Erläuterungen Remarks Remarques
11523	 4 057822 115234			
		81 25921 6043	Kohlebürstensatz Carbon brush set Balai d'alternateur	
				
10847	 4 057822 108472			
		50 0024 1417	Magnetschalter Solenoid switch Electrovalve	24 V
				
10851	 4 057822 108519			
		51 26101 7092 51 26201 7109 51 26201 7125	Anlasser Starter motor Démarreur	24V / 5.4KW
				
23472	 4 057822 234720			
		81 25921 6058	Kohlebürstensatz Carbon brush set Balai d'alternateur	
				
22108	 4 057822 221089			
		51 26101 9214	Generator Alternator Générateur	
				

KTK No.	RF No.	Bezeichnung Description Désignation	Erläuterungen Remarks Remarques
13865			
	 4 057822 138653		81 25509 0119 Schalter 81 25509 0093 Switch, indicator Interrupteur F90 TGA L2000
16445			
	 4 057822 164454		81 25509 0144 Schalter 81 25509 0085 Switch, indicator 81 25509 0118 Interrupteur 81 25509 0123 TGA

KTK No.

11126



























4 057822 111267















RF No.















51 27421 0009















**Bezeichnung
Description
Désignation**Öldruckgeber
Oil pressure sensor
Capteur de pression d'huile**Erläuterungen
Remarks
Remarques**















KTK No.	RF No.	Bezeichnung Description Désignation	Erläuterungen Remarks Remarques
20687	 4 057822 206871	 81 43610 6061 Niveauventil Level valve Valve de nivellement	
20688	 4 057822 206888	 81 25937 0015 Wegsensor 81 25937 0010 Sensor, Air valve Capteur de distance	
20703	 4 057822 207038	 81 52452 6016 / 81 52452 6017 81 52452 6019 / 81 52452 6020 81 52452 6021 / 81 52452 6024 81 52452 6025 / 81 52452 9016 81 52452 9024 / 81 52452 9025 81 52452 5019	Wegsensor Solenoid valve, ABS Capteur de distance
20704	 4 057822 207045	 81 74920 6017 Magnetventil Solenoid valve Electrovalve	
21664	 4 057822 216641	 81 52101 9270 Air valve	

KTK No.	RF No.	Bezeichnung Description Désignation	Erläuterungen Remarks Remarques
17834			
 4 057822 178345			
 	81 25101 6290	Hauptscheinwerfer Head lamp RH Phare principal	F2000
17835			
 4 057822 178352			
 	81 25101 6289	Hauptscheinwerfer Head lamp LH Phare principal	F2000
17836			
 4 057822 178369			
 	81 25101 6449 81 25101 6351	Hauptscheinwerfer Head lamp RH with rubber Phare principal	TGA
17837			
 4 057822 178376			
 	81 25101 6448 81 25101 6352	Hauptscheinwerfer Head lamp LH with rubber Phare principal	TGA
17838			
 4 057822 178383			
 	81 25101 6453 81 25101 6357 81 25101 6427 81 25101 6457	Hauptscheinwerfer Head lamp LH Phare principal	TGA

KTK No.		RF No.	Bezeichnung Description Désignation	Erläuterungen Remarks Remarques
17839	 4 057822 178390			
 		81 25101 6452 81 25101 6348 81 25101 6356 81 25101 6420 81 25101 6428 81 25101 6456	Hauptscheinwerfer Head lamp RH Phare principal	TGA
19140	 4 057822 191405			
 		81 25101 6500 81 25101 6496 81 25101 6498	Hauptscheinwerfer Head lamp RH Phare principal	TGX
19141	 4 057822 191412			
 		81 25101 6501	Hauptscheinwerfer Head lamp LH Phare principal	TGX
19142	 4 057822 191429			
 		81 25101 6504	Hauptscheinwerfer Head lamp RH (Electric) Phare principal	TGX
19143	 4 057822 191436			
 		81 25101 6503	Hauptscheinwerfer Head lamp LH (Electric) Phare principal	TGX

KTK No.	RF No.	Bezeichnung Description Désignation	Erläuterungen Remarks Remarques
20013			
 4 057822 200138			
 	81 25260 6101 81 25260 6096 81 25260 6097	Seitenmarkierungsleuchte Side marker light Feu de gabarit latéral	TGA
20025			
 4 057822 200251			
 	81 25320 6090	Nebelscheinwerfer Fog lamp RH Phare anti-brouillard	TGA
20026			
 4 057822 200268			
 	81 25320 6089	Nebelscheinwerfer Fog lamp LH Phare anti-brouillard	TGA
20027			
 4 057822 200275			
 	81 25101 6522	Nebelscheinwerfer Fog lamp RH Phare anti-brouillard	TGX/TGS
20028			
 4 057822 200282			
 	81 25101 6521	Nebelscheinwerfer Fog lamp LH Phare anti-brouillard	TGX/TGS

KTK No.		RF No.	Bezeichnung Description Désignation	Erläuterungen Remarks Remarques
20029	 4 057822 200299			
	 	81 25260 6099	Umrissleuchte Sun visor lamp Feu de gabarit	TGX
17840	 4 057822 178406			
	 	81 25320 6101	Blinkleuchte, weiß Indicator light Feu clignotant, blanc	TGA
17841	 4 057822 178413			
	 	81 25320 6112 81 25320 6092	Nebelscheinwerfer Fog lamp RH Phare anti-brouillard	TGA
17842	 4 057822 178420			
	 	81 25320 6111 81 25320 6091	Nebelscheinwerfer Fog lamp LH Phare anti-brouillard	TGA
17843	 4 057822 178437			
	 	81 25225 6545	Rückleuchte, rechts Rear lamp RH Feu arrière, droite	TGA

KTK No.		RF No.	Bezeichnung Description Désignation	Erläuterungen Remarks Remarques
17844	 4 057822 178444			
	 	81 25225 6544	Rückleuchte, links Rear lamp LH Feu arrière, droite	TGA
17845	 4 057822 178451			
	 	81 25229 6060	Rückleuchte, rechts Rear lamp lens RH Feu arrière, gauche	TGA
17846	 4 057822 178468			
	 	81 25229 6059	Rear lamp lens LH	
20014	 4 057822 200145			
	 	81 25225 6524 81 25225 6519	Rückleuchtenglas Rear lamp RH Glace de feu arrière	TGA
20023	 4 057822 200237			
	 	81 25225 6523	Rückleuchte, links Rear lamp LH Feu arrière, droite	TGA

KTK No.	RF No.	Bezeichnung Description Désignation	Erläuterungen Remarks Remarques
---------	--------	---	---------------------------------------

20024



81 25229 6052 Rear lamp lens
81 25229 6051



23142



81 25101 6450 Hauptscheinwerfer TGA
81 25101 6352 Head lamp (With motor) Right
81 25101 6422 Phare principal
81 25101 6430
81 25101 6458
81 25101 6587



23141



81 25101 6451 Hauptscheinwerfer TGA
81 25101 6351 Head lamp (With motor) Left
81 25101 6421 Phare principal
81 25101 6429
81 25101 6459



20561



Rotating Light 12V















20562









Rotating Light 24V

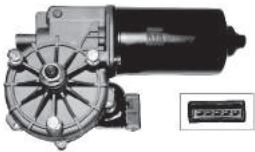

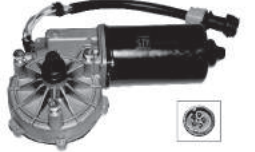
KTK No.	RF No.	Bezeichnung Description Désignation	Erläuterungen Remarks Remarques
19827	 4 057822 198275		
		81 25505 0930	Schalter Switch, reverse light Interrupteur
08906	 4 057822 089061		
		81 25505 0538	Schalter Switch, reverse light Interrupteur

KTK No.	RF No.	Bezeichnung Description Désignation	Erläuterungen Remarks Remarques
23505	 4 057822 235055		
		81 25311 0006	Blinkrelais Turn signal relay Relais de clignotant
23506	 4 057822 235062		
		81 25311 0023	Blinkrelais Turn signal relay Relais de clignotant

KTK No.	RF No.	Bezeichnung Description Désignation	Erläuterungen Remarks Remarques
21840	 4 057822 218409		
		81 26401 6132 8126401 6133 8126401 6135 8126401 6139 8126401 6140 8126401 6141 8126401 6142 8126401 6143	Wischermotor Wiper motor Moteur d'essuie-glace TGA
21839	 4 057822 218393		
		81 26401 6119 81 26401 6088 81 26401 6094 81 26401 6115 81 26401 6119 81 26401 6126 81 26401 6134	Wischermotor Wiper motor Moteur d'essuie-glace TGA
21841	 4 057822 218416		
		81 26411 6111 81 26411 6097 81 26411 6118	Wischergestänge Wiper linkage set Tringlerie d'essuie-glace





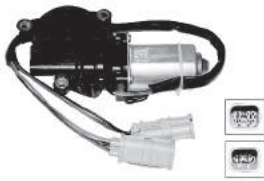









KTK No.

21842

RF No.**Bezeichnung
Description
Désignation****Erläuterungen
Remarks
Remarques**

81 28601 6143

Fensterhebermotor
Window lift motor
Moteur de lève-vitre

KTK No.	RF No.	Bezeichnung Description Désignation	Erläuterungen Remarks Remarques	
11017	 4 057822 110178			
		81 30550 0063	Ausrücklager Release bearing Butée d'embrayage	F2000/F90 TGA
15363	 4 057822 153632			
		81 30300 6002 81 30300 6003	Ausrückring Release ring Bague de débrayage	
11024	 4 057822 110246			
		81 30550 0056	Ausrücklager Release bearing Butée d'embrayage	
11034	 4 057822 110345			
		81 30550 0050	Ausrücklager Release bearing Butée d'embrayage	M90
11021	 4 057822 110215			
		81 30550 0060	Ausrücklager Release bearing Butée d'embrayage	

KTK No.

15364

RF No.

**Bezeichnung
Description
Désignation**

**Erläuterungen
Remarks
Remarques**

















4 057822 153649





























81 30300 6004















Ausrückring
Release ring
Bague de débrayage



KTK No.		RF No.	Bezeichnung Description Désignation	Erläuterungen Remarks Remarques
10907	 4 057822 109073			
			Kupplungsservo Clutch servo Servo d'embrayage	970 051 1132
				
16181	 4 057822 161811			
		81 30725 6062 81 30725 9062	Kupplungsservo Clutch servo Servo d'embrayage	
				
16116	 4 057822 161163			
		81 30725 6065 81 30725 6086 81 30725 6093 81 30725 9086	Kupplungsservo Clutch servo Servo d'embrayage	F2000
				
16134	 4 057822 161347			
		85 30001 9892 99 11423 0061 99 11423 0001	Kupplungsservo Clutch servo Servo d'embrayage	
				
10920	 4 057822 109202			
		81 30725 6031 81 30725 6032	Kupplungsservo Clutch servo Servo d'embrayage	
				

KTK No.	RF No.	Bezeichnung Description Désignation	Erläuterungen Remarks Remarques
10921			
 <p>4 057822 109219</p>			
 	<p>81 30725 6014 81 30725 6026</p>	<p>Kupplungsservo Clutch servo Servo d'embrayage</p>	
12265			
 <p>4 057822 122652</p>			
 		<p>Kupplungsservo Clutch servo Servo d'embrayage</p>	<p>VG3204</p>
20018			
 <p>4 057822 200183</p>			
 	<p>81 30725 6084</p>	<p>Kupplungsservo Clutch servo Servo d'embrayage</p>	
19718			
 <p>4 057822 197186</p>			
 	<p>81 30715 6135</p>	<p>Kupplungszylinder Clutch cylinder Cylindre d'embrayage</p>	
19713			
 <p>4 057822 197131</p>			
 	<p>81 30715 6152 81 08340 0143</p>	<p>Kupplungszylinder Clutch cylinder Cylindre d'embrayage</p>	<p>TGA 18-41</p>

KTK No.	RF No.	Bezeichnung Description Désignation	Erläuterungen Remarks Remarques
10919	 4 057822 109196		
 	81 32735 6011 81 32735 9011	Zylinder Shift cylinder Cylindre	M90
19455	 4 057822 194550		
 	81 32655 6181	Zylinder Shift cylinder Cylindre	
19454	 4 057822 194543		
 	81 32655 6182 81 32655 6115	Zylinder Shift cylinder Cylindre	
20818	 4 057822 208189		
 	81 30715 6132	Zylinder Clutch cylinder Cylindre	

KTK No.	RF No.	Bezeichnung Description Désignation	Erläuterungen Remarks Remarques
08880	 4 057822 088804	 81 95301 6064 Kugelgelenk 81 95301 6130 Ball joint 81 95301 6170 Rotule 81 95301 6173	M12 - R/H L : 55 F2000/F90 M2000/M90
			
08881	 4 057822 088811	 81 95301 6063 Kugelgelenk 81 95301 6131 Ball joint 81 95301 6171 Rotule 81 95301 6174	M12 - L/H
			
08882	 4 057822 088828	 81 95301 0038 Kugelgelenk 81 95301 0045 Ball joint 81 95301 6016 Rotule 81 95301 6169	R/H L=86 M14x1.5 F4/6 - FL4/6
			
16748	 4 057822 167486	 81 95301 6144 Kugelgelenk 06 36090 0605 Ball joint RH 81 95301 7004 Rotule	M8x1.25 Rx47 TGA/F2000
			
19288	 4 057822 192884	 81 95301 6204 Kugelgelenk Ball joint LH Rotule	8x1.25 TGA/F2000
			

KTK No.

13775

RF No.**Bezeichnung
Description
Désignation****Erläuterungen
Remarks
Remarques**

4 057822 137755



81 95301 6280

Kugelgelenk
Ball joint RH
RotuleM26x1.5
L = 75

KTK No.	RF No.	Bezeichnung Description Désignation	Erläuterungen Remarks Remarques
---------	--------	---	---------------------------------------

08968























81 96503 0236

Wellendichtring
Oil seal, transmission
Bague d'etanchéité

105x130x12



KTK No.	RF No.	Bezeichnung Description Désignation	Erläuterungen Remarks Remarques
14778	 4 057822 147785		
		81 32638 0005	Zylindergehäuse Cylinder housing Carter de cylindre
14776	 4 057822 147761		
		81 32638 0006	Zylindergehäuse Cylinder housing Carter de cylindre

KTK No.		RF No.	Bezeichnung Description Désignation	Erläuterungen Remarks Remarques
19443	 4 057822 194437			
		81 97010 6011	Schaltknauf Gear shift knob Pommeau de levier de vitesses	F90/2000 M90/2000
19446	 4 057822 194468			
		81 32620 0045 81 32620 0083 81 32620 0076	Schaltknauf Gear shift knob Pommeau de levier de vitesses	
19447	 4 057822 194475			
		81 32620 0039 81 32620 0043	Schaltknauf Gear shift knob Pommeau de levier de vitesses	
23043	 4 057822 230432			
		81 32620 0049	Schaltknauf Gear shift knob Pommeau de levier de vitesses	
23044	 4 057822 230449			
		81 32620 0095	Schaltknauf Gear shift knob Pommeau de levier de vitesses	

KTK No.

22164



4 057822 221645

RF No.

81 32620 0044

**Bezeichnung
Description
Désignation**Schaltknopf
Gear shift knob
Pommeau de levier de vitesses**Erläuterungen
Remarks
Remarques**

KTK No.

19451

RF No.

**Bezeichnung
Description
Désignation**

**Erläuterungen
Remarks
Remarques**



81 32655 6129	Schaltgerät
81 32605 6111	Actuator, Gear shift
81 32655 6113	Appareil commande
81 32655 6114	
81 32655 6128	

KTK No.	RF No.	Bezeichnung Description Désignation	Erläuterungen Remarks Remarques
---------	--------	---	---------------------------------------

12087



81 93420 0133

Rollenlager
Bearing
Palier à rouleaux

62mm
4th speed gear



12079















81 93420 0040

Rollenlager
Bearing, Drive shaft front
Palier à rouleaux

84x157x28



KTK No.	RF No.	Bezeichnung Description Désignation	Erläuterungen Remarks Remarques
06487	 4 057822 064877		
 	81 32903 0116	Dichtung Gasket / Joint	
06939	 4 057822 069391		
 	81 90701 0549	Dichtung Shim Joint	149x129x.03
06940	 4 057822 069407		
 	81 32312 0153	Dichtung Shim Joint	
08984	 4 057822 089849		
 	81 96401 0148	Wellendichtring Seal Bague d'etanchéité	25x35x10/4.5

KTK No.

10914









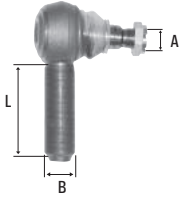

4 057822 109141

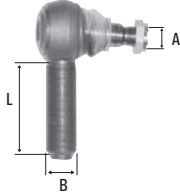
RF No.

81 52170 6128

**Bezeichnung
Description
Désignation**Ventil
Valve / Soupape**Erläuterungen
Remarks
Remarques**

KTK No.	RF No.	Bezeichnung Description Désignation	Erläuterungen Remarks Remarques
08884			
 4 057822 088842			
	81 95301 0014 81 95301 0064 81 95301 6067	Kugelgelenk Ball joint R/H Rotule	A = M20x1.5 B = M30x1.5 L = 120mm NG-LK-MK-SK
08883			
 4 057822 088835			
	81 95301 0013 81 95301 0074	Kugelgelenk Ball joint L/H Rotule	A = M20x1.5 B = M30x1.5 L = 120mm
13366			
 4 057822 133665			
	81 95301 6297	Kugelgelenk Tie rod end R/H Rotule	135x38
08887			
 4 057822 088873			
	81 95301 0016 81 95301 6030 81 95301 6048 81 95301 6053	Kugelgelenk Tie rod end R/H Rotule	M24x1.5 M30x1.5 L = 120mm
08888			
 4 057822 088880			
	81 95301 0015 81 95301 6029	Kugelgelenk Tie rod end L/H Rotule	

KTK No.	RF No.	Bezeichnung Description Désignation	Erläuterungen Remarks Remarques
---------	--------	---	---------------------------------------









12815























81 95308 5002

Manschette
Boot / Manchon

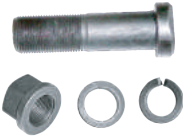

KTK No.	RF No.	Bezeichnung Description Désignation	Erläuterungen Remarks Remarques
19186			
 4 057822 191863			
 	81 46610 6722 81 46610 6216 81 46610 6333 81 46610 6334 81 46610 6354 81 46610 6355 81 46610 6360	Lenkstange Drag Link Barre de direction 81 46610 6361 81 46610 6721 81 46610 6723	L = 1040mm F2000/F90
21603			
 4 057822 216030			
 	81 46611 6197	Lenkstange Drag Link Barre de direction	L = 936mm TGA 2000/03 TGS 2007/08 TGX 2007/09
21604			
 4 057822 216047			
 	81 46711 6858 81 46711 6773 81 46711 6791 81 46711 6848 81 46711 6859 81 46711 6861	Lenkstange Drag Link Barre de direction	L = 1610mm TGA 2000/03 TGS 2007/08 TGX 2007/09

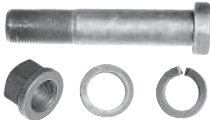
KTK No.	RF No.	Bezeichnung Description Désignation	Erläuterungen Remarks Remarques
09110	 4 057822 091101		
		06 11222 0218	Radmutter Wheel nut / Ecrou de roue
			SW30, M22x1.5 F2000/F90 M2000/M90
09115	 4 057822 091156		
		81 45502 0001	Scheibe Washer / Rondelle
			F90/M90
18511	 4 057822 185114	81 45422 0023 81 45422 0037	Bolzen mit Mutter Bolt with nut Jeu d'axes
		81 45422 0023	125x18x2
18512	 4 057822 185121		
		81 45422 0060	Bolzen mit Mutter Bolt with nut Jeu d'axes
			115x20x2
18010	 4 057822 180102		
		81 45501 0067A	Bolzen mit Mutter Bolt with nut Jeu d'axes
			110x22x1.5

KTK No.	RF No.	Bezeichnung Description Désignation	Erläuterungen Remarks Remarques
09111	 4 057822 091118	 Bolzen mit Mutter Bolt with nut Jeu d'axes	09114 - 1Nos. 09115 - 1Nos. 80x22x1.5
11850	 4 057822 118501	81 45501 0076 Radbolzen Wheel bolt Goujon de roue	
09113	 4 057822 091132	 Reparatursatz Repair kit Kit de réparation	09114 - 1Nos. 09115 - 1Nos. 09110 - 1Nos. 110x22x1.5
11849	 4 057822 118495	81 45501 0082 Radbolzen Wheel bolt Goujon de roue	
08818	 4 057822 088187	81 45503 0026 Radmutter Wheel Nut / Ecrou de roue	SW32, M22x1.5



KTK No.	RF No.	Bezeichnung Description Désignation	Erläuterungen Remarks Remarques
---------	--------	---	---------------------------------------















09114











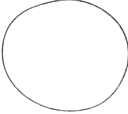













81 45504 0008





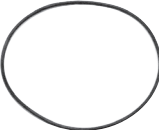









Scheibe
Washer / Rondelle



KTK No.	RF No.	Bezeichnung Description Désignation	Erläuterungen Remarks Remarques
07704	 4 057822 077044		
		81 90685 0303	Flachbundmutter Flat collar nut Ecrou double-hexagonal
07705	 4 057822 077051		
		81 35710 0044	Druckring Thrust ring Frêt de joint speed
07715	 4 057822 077150		
		81 35710 0045	Druckring Thrust ring Frêt de joint speed
15538	 4 057822 155384		
		81 35710 6009	Druckring Thrust ring Frêt de joint speed
15537	 4 057822 155377		
		81 35710 0067	Druckring Thrust ring Frêt de joint speed

KTK No.		RF No.	Bezeichnung Description Désignation	Erläuterungen Remarks Remarques
09899	 4 057822 098995			
		06 56341 4254	O-Ring O-ring / Joint torique	
09616	 4 057822 096168			
		06 56289 0064	Wellendichtring Seal Bague d'etanchéité	145x175x14/12
09617	 4 057822 096175			
		81 96503 0154	Wellendichtring Seal Bague d'etanchéité	145x175x13
12585	 4 057822 125851			
		06 56289 0371	Wellendichtring Oil seal, rear wheel Bague d'etanchéité	145x175/205x9/14 TGA F2000/F90 M2000/M90
12586	 4 057822 125868			
		06 56289 0319	Wellendichtring Oil seal, differential Bague d'etanchéité	85x145x12/37 TGA F2000/F90

KTK No.	RF No.	Bezeichnung Description Désignation	Erläuterungen Remarks Remarques
15829	 4 057822 158293		
		06 56279 0362	Wellendichtring Oil seal, differential Bague d'etanchéité
07537	 4 057822 075378		
		51 96501 0265	O-Ring O-ring / Joint torique
19781	 4 057822 197810		
		81 96601 0298	Dichtung Gasket, rear axle cover Joint

KTK No.		RF No.	Bezeichnung Description Désignation	Erläuterungen Remarks Remarques
06516	 4 057822 065164			
		81 90001 0184	Bolzen mit Mutter Bolt with nut Jeu d'axes	10.9 M16 x 1.5 x 45
				
07702	 4 057822 077020			
		81 90640 0032	Flachbundmutter Flat collar nut Ecrou double-hexagonal	M45 x 1.5, SW 55
				
07716	 4 057822 077167			
		81 90620 0048	Nutmutter Grooved nut Ecrou à gorge	
				
07929	 4 057822 079291			
		81 35608 0024	Spinne Spider / Araignée	
				
07931	 4 057822 079314			
		06 02190 2610 06 02099 0204	Schraube Screw - L key Vis	
				

KTK No.	RF No.	Bezeichnung Description Désignation	Erläuterungen Remarks Remarques
---------	--------	---	---------------------------------------









10180

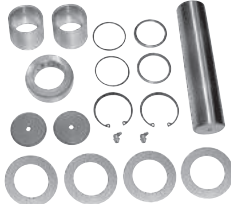

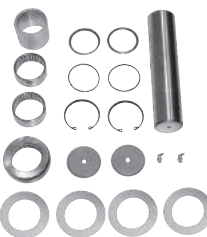





















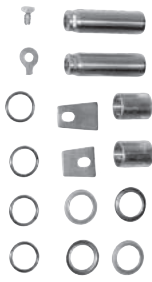

81 35204 0015

Scheibe
Washer / Rondelle



KTK No.	RF No.	Bezeichnung Description Désignation	Erläuterungen Remarks Remarques
08679			
  <p>4 057822 086794</p> 	81 44205 6010	Reparatursatz Repair kit, king pin Kit de réparation	SG/SL/SR φ49.5/50x223
08680			
  <p>4 057822 086800</p> 	81 44205 6013	Reparatursatz Repair kit, king pin Kit de réparation	F2000/M2000 F90 φ49.5/50x223
17286			
  <p>4 057822 172862</p> 	81 44205 6031 81 44205 6030	Reparatursatz Repair kit, king pin Kit de réparation	TGA/TGS/TGX φ53x235

KTK No.	RF No.	Bezeichnung Description Désignation	Erläuterungen Remarks Remarques
06562	 4 057822 065621		
 	81 97610 0123	Feder Spring / Ressort	TGA F2000/F90 M2000/M90 Rear Axle Brake lining 220mm
06561	 4 057822 065614		
 	81 97610 0118 81 97610 0208	Feder Spring / Ressort Brake lining	F90 Front axle 160mm
15041	 4 057822 150419		
 	81 97610 0210	Feder Spring / Ressort	228X104
06554	 4 057822 065546		
 	81 97610 0210	Feder Spring / Ressort	228X104

KTK No.	RF No.	Bezeichnung Description Désignation	Erläuterungen Remarks Remarques
<p>07737</p>  <p>4 057822 077372</p>  	<p>81 50212 0036S</p>	<p>Reparatursatz Repair kit brake shoe Kit de réparation</p>	<p>F2000/F90 M2000/M90</p>
<p>22590</p>  <p>4 057822 077389</p>  	<p>81 50212 0032 81 50212 0036</p>	<p>Brake shoe pin</p>	
<p>07740</p>  <p>4 057822 077402</p>  	<p>81 93020 0576</p>	<p>Buchse Bushing / Bague</p>	
<p>07739</p>  <p>4 057822 077396</p>  	<p>81 90801 0225</p>	<p>Sicherungsblech Lock plate Tôle de fixation</p>	

KTK No.	RF No.	Bezeichnung Description Désignation	Erläuterungen Remarks Remarques
---------	--------	---	---------------------------------------

08546



81 50301 0113 Bremsnockenwelle, links
 81 50301 0263 Camshaft LH
 81 50301 0265 Arbre á came de frein, gauche



08547



81 50301 0112 Bremsnockenwelle, rechts
 81 50301 0262 Camshaft RH
 81 50301 0264 Arbre á came de frein, droite
 Die verwendeten



16853



81 50301 0283 Bremsnockenwelle, links Front
 Camshaft LH L = 255
 Arbre á came de frein, gauche





























16854























81 50301 0224 Bremsnockenwelle, rechts
 Camshaft RH
 Arbre á came de frein, droite



KTK No.	RF No.	Bezeichnung Description Désignation	Erläuterungen Remarks Remarques
06646	 4 057822 066468		
		81 50610 6187	Gestängesteller, automatisch Automatic Slack adjuster Levier régleur, automatique
06647	 4 057822 066475		
		81 50610 6188	Gestängesteller, automatisch Automatic Slack adjuster Levier régleur, automatique
15820	 4 057822 158200		
		81 50610 6261	Gestängesteller, automatisch Automatic Slack adjuster LH Levier régleur, automatique TGA
15821	 4 057822 158217		
		81 50610 6262	Gestängesteller, automatisch Automatic Slack adjuster RH Levier régleur, automatique TGA
13255	 4 057822 132552		
		81 50610 6213	Gestängesteller, automatisch Automatic Slack adjuster Levier régleur, automatique LH

KTK No.	RF No.	Bezeichnung Description Désignation	Erläuterungen Remarks Remarques
13256	 4 057822 132569		
		81 50610 6212	Gestängesteller, automatisch Automatic Slack adjuster Levier régleur, automatique RH
13570	 4 057822 135706		
		81 50610 6211	Gestängesteller, automatisch Automatic Slack adjuster Levier régleur, automatique REAR
13571	 4 057822 135713		
		81 50610 6210	Gestängesteller, automatisch Automatic Slack adjuster Levier régleur, automatique REAR
23041	 4 057822 230418		
		81 50610 6263 81 50610 6253	Gestängesteller, automatisch Automatic Slack adjuster Levier régleur, automatique LH

KTK No.	RF No.	Bezeichnung Description Désignation	Erläuterungen Remarks Remarques	
06526	 4 057822 065263			
		81 50610 6051	Gestängesteller Slack adjuster Levier régleur	L = 161 R.H.
06527	 4 057822 065270			
		81 50610 6052	Gestängesteller Slack adjuster Levier régleur	L = 161 L.H.
17085	 4 057822 170851			
		81 50610 6132	Reparatursatz Repair kit Kit de réparation	

KTK No.	RF No.	Bezeichnung Description Désignation	Erläuterungen Remarks Remarques
15542	 4 057822 155421		
		81 50803 0009 Bremsscheibe Brake disc frein à disque	F2000 / F90 M2000 Front Axle 200x438
15543	 4 057822 155438		
		81 50803 0040 Bremsscheibe Brake disc frein à disque	12 Hole TGA F2000/M2000 Front Axle 196x432
22727	 4 057822 227272		
		81 50803 0044 Bremsscheibe Brake disc frein à disque	TGA
21099	 4 057822 210991		
		81 50803 0041 Bremsscheibe Brake disc frein à disque	F 2000

KTK No.

RF No.

**Bezeichnung
Description
Désignation**

**Erläuterungen
Remarks
Remarques**

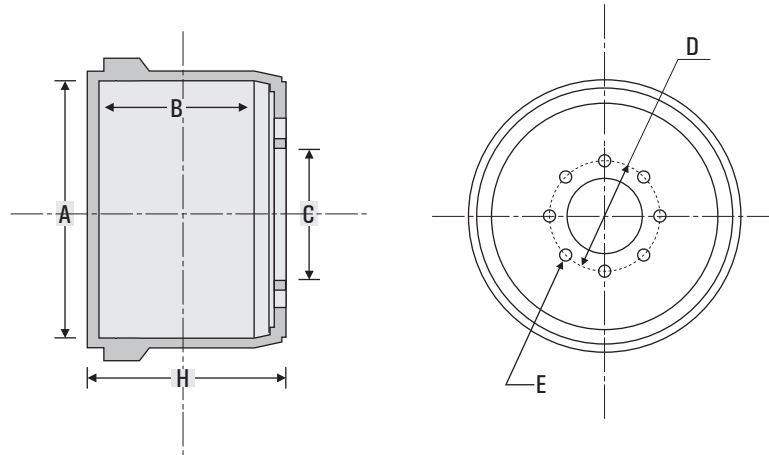

15793



81 50110 0144

**Bremstrommel
Brake drum rear
Tambour de frein**

A = 410mm
B = 234mm
H = 300mm
C = 298mm
D = 335mm
E = 23mm
10 Hole











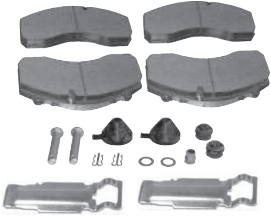

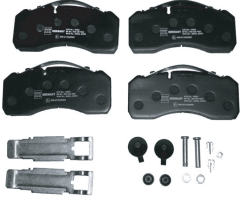
15794













81 50110 0232















**Bremstrommel
Brake drum Front
Tambour de frein**











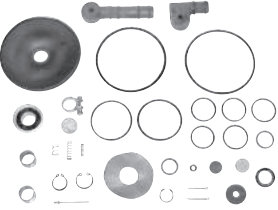



A = 410mm
B = 187mm
H = 232mm
C = 298mm
D = 335mm
E = 23mm
10 Hole















KTK No.	RF No.	Bezeichnung Description Désignation	Erläuterungen Remarks Remarques
<p data-bbox="284 197 357 226">12091</p>  <p data-bbox="520 264 687 286">4 057822 120917</p>  	<p data-bbox="751 371 932 405">81 50820 5099</p> <p data-bbox="751 409 932 443">81 50820 6030</p> <p data-bbox="751 448 932 481">81 50820 6056</p>	<p data-bbox="995 371 1461 405">Scheibenbremsbelagsatz TGA/TGS/TGX</p> <p data-bbox="995 409 1145 443">Brake pad set</p> <p data-bbox="995 448 1374 481">Kit de garnitures de frein à disques</p>	
<p data-bbox="284 595 357 624">16364</p>  <p data-bbox="520 663 687 685">4 057822 163648</p>  	<p data-bbox="751 730 932 763">81 50820 6059</p> <p data-bbox="751 768 932 801">81 50820 6060</p> <p data-bbox="751 806 932 840">81 50820 5098</p>	<p data-bbox="995 730 1382 763">Scheibenbremsbelagsatz M2000</p> <p data-bbox="995 768 1145 801">Brake pad set</p> <p data-bbox="995 806 1209 875">Kit de garnitures de frein à disques</p>	
<p data-bbox="284 983 357 1012">16365</p>  <p data-bbox="520 1050 687 1072">4 057822 163655</p>  	<p data-bbox="751 1133 932 1167">81 50820 6046</p>	<p data-bbox="995 1133 1461 1279">Scheibenbremsbelagsatz TGA Brake pad set F2000/M2000 Kit de garnitures de frein à disques Front Axle</p>	
<p data-bbox="284 1370 357 1400">19377</p>  <p data-bbox="520 1438 687 1460">4 057822 193775</p>  	<p data-bbox="751 1527 932 1561">81 50820 5085</p> <p data-bbox="751 1565 932 1599">81 50820 6043</p> <p data-bbox="751 1603 932 1637">81 50820 6054</p>	<p data-bbox="995 1527 1374 1632">Scheibenbremsbelagsatz Brake pad set Kit de garnitures de frein à disques</p>	
<p data-bbox="284 1758 357 1787">23437</p>  <p data-bbox="520 1825 687 1848">4 057822 234379</p>  	<p data-bbox="751 1908 932 1942">81 50820 5023</p>	<p data-bbox="995 1908 1374 2018">Scheibenbremsbelagsatz Brake pad set Kit de garnitures de frein à disques</p>	





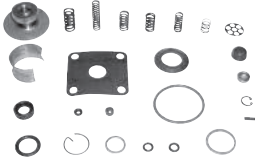







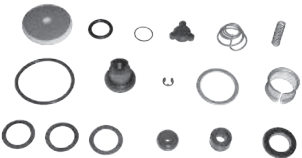

KTK No.	RF No.	Bezeichnung Description Désignation	Erläuterungen Remarks Remarques
19756	 4 057822 197568		
		N225520061	ABS Sensor Capteur ABS
19821	 4 057822 198213		
		36 27120 6005	ABS Sensor, links ABS sensor, left Capteur ABS, gauche













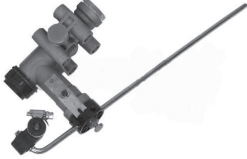

KTK No.	RF No.	Bezeichnung Description Désignation	Erläuterungen Remarks Remarques
10248			
			
	81 52102 0008	Lufttrocknerpatrone Air Filter Cartouche de déssiccateur	TGA F2000 / F90 G90 / L 2000 M2000/M90
10071			
			
	81 52185 6009	Ventil Valve, multi way Soupape	
10249			
			
	81 51230 0009 81 51230 6009	Ventil Valve, shut off cock Soupape	
10074			
			
	81 50410 6018 81 50410 6118 81 50410 6125	Federspeicherbremszylinder Brake Booster Cylindre de frein à ressort accumulateur	
08946			
			
	81 50400 6027	Reparatursatz Brake booster repair kit Kit de réparation	









KTK No.	RF No.	Bezeichnung Description Désignation	Erläuterungen Remarks Remarques
08947			
 4 057822 089474			
 	81 50410 6135	Reparatursatz Brake booster repair kit Kit de réparation	
10910			
 4 057822 109103			
 	81 52101 6147 81 52101 9147	Ventil Valve, pressure limiting Soupape	
10913			
 4 057822 109134			
 	81 52185 6015 81 52185 6016	Ventil Valve, multiway Soupape	
10917			
 4 057822 109172			
 	81 52116 6008 81 52116 6010	Ventil Relay vale Soupape	
10922			
 4 057822 109226			
 	81 52161 9174	Ventil Valve, brake power Soupape	

KTK No.	RF No.	Bezeichnung Description Désignation	Erläuterungen Remarks Remarques
<p data-bbox="280 197 360 226">08948</p>  <p data-bbox="523 264 691 286">4 057822 089481</p>  	<p data-bbox="754 371 930 400">81 52161 6258</p>	<p data-bbox="995 371 1182 479">Reparaturatz Repair kit Kit de réparation</p>	
<p data-bbox="280 595 360 624">08953</p>  <p data-bbox="523 663 691 685">4 057822 089535</p>  	<p data-bbox="754 730 930 759">81 52161 6269</p>	<p data-bbox="995 730 1182 837">Reparaturatz Repair kit Kit de réparation</p>	
<p data-bbox="280 981 360 1010">11107</p>  <p data-bbox="523 1048 691 1070">4 057822 111076</p>  	<p data-bbox="754 1133 930 1200">81 52130 6031 81 52130 6048</p>	<p data-bbox="995 1133 1134 1240">Ventil Valve, brake Soupape</p>	
<p data-bbox="280 1366 360 1395">12255</p>  <p data-bbox="523 1433 691 1456">4 057822 122553</p>  	<p data-bbox="754 1500 930 1529">81 52315 6054</p>	<p data-bbox="995 1500 1222 1608">Ventil Valve, parking brake Soupape</p>	
<p data-bbox="280 1751 360 1780">12258</p>  <p data-bbox="523 1818 691 1841">4 057822 122584</p>  	<p data-bbox="754 1906 930 1973">81 52101 6264 81 52101 6266</p>	<p data-bbox="995 1906 1155 2013">Schalldämpfer Silencer Silencieux</p>	<p data-bbox="1299 1906 1465 1973">TGA F2000/M2000</p>

KTK No.	RF No.	Bezeichnung Description Désignation	Erläuterungen Remarks Remarques
12266	 4 057822 122669		
		81 52110 6061	Ventil Overflow valve Soupape
07334	 4 057822 073343		
		81 52116 6014 81 52116 6019 81 52116 6020	Ventil Relay valve Soupape F90/M90/G90
07338	 4 057822 073381		
		81 52115 6017 81 52115 6018 81 52115 6021	Ventil Quick release valve Soupape
08936	 4 057822 089368		
		81 52101 6118	Reparatursatz Repair kit Kit de réparation
07322	 4 057822 073220		
		81 52101 6085 81 52101 6112 81 52101 6114	Ventil Unloader valve Soupape

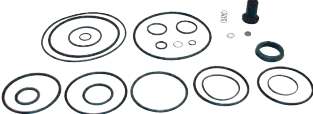
KTK No.	RF No.	Bezeichnung Description Désignation	Erläuterungen Remarks Remarques
07321			
 4 057822 073213			
 	81 52101 6017	Ventil Unloader valve Soupape	
08937			
 4 057822 089375			
 	82 52101 6019	Reparatursatz Repair kit Kit de réparation	
07331			
 4 057822 073312			
 	81 52301 6031	Ventil Control valve Soupape	
08251			
 4 057822 082512			
 	81 51101 6080 81 51101 6081 81 51101 6083	Federspeicherbremszylinder Brake Booster Cylindre de frein à ressort accumulateur	TRL 24"
17161			
 4 057822 171612			
 	81 52101 6269	Ventil Valve, pressure limiting Soupape	TGA

KTK No.	RF No.	Bezeichnung Description Désignation	Erläuterungen Remarks Remarques	
17542	 4 057822 175429			
		81 52101 6295	Ventil Valve, pressure control Soupape	TGA18/22/16/28
18603	 4 057822 186036			
		81 43610 6117 81 43610 6116	Ventil Air suspension valve Soupape	
13307	 4 057822 133078			
		85 50001 4460	Federspeicherbremszylinder Brake Booster 24"/24" Cylindre de frein à ressort accumulateur	
12257	 4 057822 122577			
		81 52130 6043	Ventil Valve Soupape	
12256	 4 057822 122560			
		81 51270 6002	Ventil Air valve Soupape	20 bar

KTK No.	RF No.	Bezeichnung Description Désignation	Erläuterungen Remarks Remarques
12252	 4 057822 122522	 82 52301 6015	Ventil Air valve Soupape
12250	 4 057822 122508	 81 52301 6184	Ventil Air valve Soupape
12251	 4 057822 122515	 81 52301 6193	Reparatursatz Repair kit Kit de réparation
08253	 4 057822 082536	 81 52101 6085	Ventil Unloader valve Soupape
07324	 4 057822 073244	 85 50001 4354	Ventil Foot Brake Valve Soupape

KTK No.	RF No.	Bezeichnung Description Désignation	Erläuterungen Remarks Remarques
---------	--------	---	---------------------------------------

07333



81 99164 3679
81 43609 6008

Ventil
Relay valve
Soupape

Thread 1 : M22x1.5
Thread 2 : M22x1.5

07339



81 52131 6001

Ventil
Air valve
Soupape

10911



88 52315 6211

Ventil
Air valve
Soupape

11113



82 52101 6036





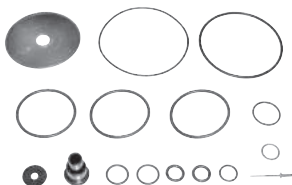



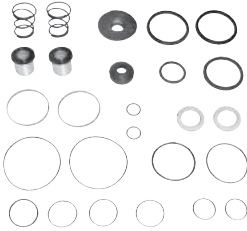

Ventil
Air valve
Soupape















08942









81 52301 6069

Reparatursatz
Repair kit
Kit de réparation

KTK No.	RF No.	Bezeichnung Description Désignation	Erläuterungen Remarks Remarques
<p data-bbox="279 197 359 230">08940</p>  <p data-bbox="523 257 691 280">4 057822 089405</p>  	<p data-bbox="753 369 933 403">81 52161 6258</p>	<p data-bbox="997 369 1181 481">Reparaturatz Repair kit Kit de réparation</p>	
<p data-bbox="279 595 359 629">07787</p>  <p data-bbox="523 656 691 678">4 057822 077877</p>  	<p data-bbox="753 734 933 768">81 51260 6003</p> <p data-bbox="753 772 933 806">81 51260 7004</p> <p data-bbox="753 810 933 844">84 51260 6004</p>	<p data-bbox="997 734 1220 768">Entwässerungsventil</p> <p data-bbox="997 772 1125 806">Drain Valve</p> <p data-bbox="997 810 1220 844">Valve de purge d'eau</p>	<p data-bbox="1300 734 1460 768">M22 x 1.5mm</p> <p data-bbox="1300 772 1412 806">SW27mm</p>
<p data-bbox="279 981 359 1014">20678</p>  <p data-bbox="523 1041 691 1064">4 057822 206789</p>  	<p data-bbox="753 1120 933 1153">81 52151 6095</p> <p data-bbox="753 1158 933 1191">81 52151 6098</p>	<p data-bbox="997 1120 1197 1153">Kreis-Schutzventil</p> <p data-bbox="997 1158 1252 1191">Circuit protection valve</p> <p data-bbox="997 1196 1204 1229">Valve de protection</p>	
<p data-bbox="279 1366 359 1400">23763</p>  <p data-bbox="523 1426 691 1449">4 057822 237639</p>  	<p data-bbox="753 1505 933 1538">81 50410 6540</p> <p data-bbox="753 1543 933 1576">81 50410 6610</p> <p data-bbox="753 1581 933 1615">81 50410 6620</p>	<p data-bbox="997 1505 1300 1538">Federspeicherbremszylinder</p> <p data-bbox="997 1543 1157 1576">Brake Booster</p> <p data-bbox="997 1581 1436 1615">Cylindre de frein à ressort accumulateur</p>	<p data-bbox="1364 1505 1436 1538">24/24</p> <p data-bbox="1364 1543 1436 1576">OTGA</p>

KTK No.	RF No.	Bezeichnung Description Désignation	Erläuterungen Remarks Remarques
07742	 4 057822 077426		
		81 51113 0019	Membrane Diaphragm
07743	 4 057822 077433		
		81 51113 0013	Membrane Diaphragm
07744	 4 057822 077440		
		81 51113 0001	Membrane Diaphragm
07745	 4 057822 077457		
		81 51113 0002	Membrane Diaphragm
07746	 4 057822 077464		
		90 91159 0013	Membrane Diaphragm

KTK No.	RF No.	Bezeichnung Description Désignation	Erläuterungen Remarks Remarques
07748			
 4 057822 077488			
 	81 51113 0007 81 51113 0012	Membrane - lang Diaphragm long stroke Membrane - longue	T 16
07749			
 4 057822 077495			
 	81 51113 0020	Membrane - lang Diaphragm long stroke Membrane - longue	T 20
07750			
 4 057822 077501			
 	81 51113 0017 81 51113 0014	Membrane - lang Diaphragm long stroke Membrane - longue	T 24

KTK No.

11114











RF No.**Bezeichnung
Description
Désignation****Erläuterungen
Remarks
Remarques**





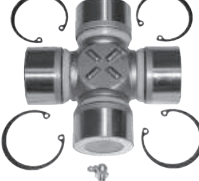







4 057822 111144





















81 26485 6016

Wischwasserpumpe
Washer pump
Pompe de lave glace













KTK No.	RF No.	Bezeichnung Description Désignation	Erläuterungen Remarks Remarques
13257	 4 057822 132576	81 39126 6020  	Zapfenkreuz Universal joint cross Croisillon 52x147 F2000 / F90
15758	 4 057822 157586	85 30002 0399 81 39200 6011 81 39126 6007  	Zapfenkreuz Universal joint cross Croisillon 48x116.50
10164	 4 057822 101640	81 39200 6016  	Zapfenkreuz Universal joint cross Croisillon 52.03X133mm F90/M90 NG/NL
10166	 4 057822 101664	81 39126 6006  	Zapfenkreuz Universal joint cross Croisillon 57x152mm

KTK No.	RF No.	Bezeichnung Description Désignation	Erläuterungen Remarks Remarques
13716	 4 057822 137168	  81 39410 6020	Gummilager Central rubber bearing Silentbloc 75x20 φ TGA Hole pitch : 230mm
13721	 4 057822 137212	  81 39400 6107	Gummilager Central rubber bearing Silentbloc 75x20 φ Hole pitch : 220mm
14589	 4 057822 145897	  81 39410 6019	Gummilager Central rubber bearing Silentbloc 65x23 φ F2000 / F90 TGA /M2000/90
16132	 4 057822 161323	  81 39410 6023 81 39410 6031	Gummilager Central rubber bearing Silentbloc 85mm F2000/F90 L2000

KTK No.		RF No.	Bezeichnung Description Désignation	Erläuterungen Remarks Remarques
08464	 4 057822 084646			
		81 43270 6040	Reparatursatz Repair kit Kit de réparation	95mm ϕ MAN 292/332/362 SG 242/282/280/292/322 SL 200/ 202 SR 240/280 SUE 240/242/280
09084	 4 057822 090845			
		81 95302 0039	Reparatursatz Repair kit Kit de réparation	85mm ϕ SL200/SU240
21229				
		81 43270 6105	Reparatursatz Repair kit Kit de réparation	85x25x130 TGA
12761	 4 057822 127619			
		81 43220 6206	Reparatursatz Repair kit Kit de réparation	67mm ϕ
19980	 4 057822 199807			
		81 43230 6061	Reparatursatz Repair kit Kit de réparation	75mm ϕ

KTK No.	RF No.	Bezeichnung Description Désignation	Erläuterungen Remarks Remarques
20493	 4 057822 204938	 81 43270 6119 Reparatursatz Repair kit Kit de réparation	75x19x150
11224	 4 057822 112240	 81 43270 6080 Reparatursatz Repair kit Kit de réparation	TGA/TGS/TGX
20423	 4 057822 204235	 81 43220 6108 81 43220 6132 Repair kit, balance rod	

KTK No.	RF No.	Bezeichnung Description Désignation	Erläuterungen Remarks Remarques
16411	 4 057822 164119	81 96210 0554 Gummilager 81 96210 0547 Spring Cushion RH Silentbloc	F2000/TGA H= 133
19229	 4 057822 192297	81 96210 0555 Gummilager 81 96210 0548 Spring Cushion LH Silentbloc	F2000/TGA H= 133

KTK No.	RF No.	Bezeichnung Description Désignation	Erläuterungen Remarks Remarques	
15484	 4 057822 154844			
		81 43722 0019	Buchse Bush, stabilizer Bague	F2000/F90/TGA 22x75x62
15477	 4 057822 154776			
		81 43722 0021	Buchse Bush, stabilizer Bague	65x22x62 F90/M90
15478	 4 057822 154783			
		81 43722 0047	Buchse Bush, stabilizer Bague	64x24x44 NG/NL SG/SL
15490	 4 057822 154905			
		81 43722 0062 81 43722 0045	Buchse Bush, spring leaf Bague	F2000 24x70x105

KTK No.

21230

RF No.**Bezeichnung
Description
Désignation****Erläuterungen
Remarks
Remarques**

4 057822 212308



81 43722 0061

Buchse











81 43722 0044







Bush, spring leaf

Bague



KTK No.	RF No.	Bezeichnung Description Désignation	Erläuterungen Remarks Remarques	
08665	 4 057822 086657			
		06 32490 3200	Rollenlager Wheel bearing Palier à rouleaux	F90 / N90 50x110x42/45 Front axle, Outer
10874	 4 057822 108748			
		81 93420 0270	Rollenlage Wheel bearing Palier à rouleaux	L2000/M90 75x125x37/39
10117	 4 057822 101176			
		06 32499 004	Rollenlager Wheel bearing Palier à rouleaux	70x130x58/60 F2000/M90
10118	 4 057822 101183			
		06 32499 0044	Rollenlager Wheel bearing Palier à rouleaux	110x170x47/50 TGA Rear axle inner
10873	 4 057822 108731			
			Rollenlage Wheel bearing Palier à rouleaux	95x145x32 32019

KTK No.	RF No.	Bezeichnung Description Désignation	Erläuterungen Remarks Remarques
10119	 4 057822 101190		
		06 32480 5000 Rollenlager Wheel bearing Palier à rouleaux	100x180x37
12077	 4 057822 120771		
		81 93420 0183 Rollenlage Wheel bearing Palier à rouleaux	120x180x38/40
12078	 4 057822 120788		
		06 32849 0011 Rollenlager Wheel bearing Palier à rouleaux	L2000/M90 90x140x32/35
15529	 4 057822 155292		
		06 32499 0153 06 32499 0154 81 93420 0233 Rollenlager Wheel bearing Palier à rouleaux	100x165x47/49 TGA

KTK No.	RF No.	Bezeichnung Description Désignation	Erläuterungen Remarks Remarques
12264	 4 057822 122645		
		81 47101 6008	Lenkhelfpumpe Steeing pump Pompe de direction assistée 100 MPA
21663	 4 057822 216634		
		81 47101 6162 81 47101 6137	Lenkhelfpumpe Steeing pump Pompe de direction assistée

KTK No.

19870

RF No.

**Bezeichnung
Description
Désignation**

**Erläuterungen
Remarks
Remarques**



81 47301 6030

Ölbehälter, mit Filter
Steering Oil tank
Réservoir d'huile, avec filtre

KTK No.	RF No.	Bezeichnung Description Désignation	Erläuterungen Remarks Remarques
---------	--------	---	---------------------------------------

15489



4 057822 154899



81 96210 0437CPL **Reparatursatz** **F2000/F90**
 Repair kit, driver cab suspension
 Kit de réparation

15488



4 057822 154882



81 96210 0437 **Buchse** **16.5x70.5x68**
 Bush / Bague

15487



4 057822 154875



81 96210 0462 **Buchse** **F2000/F90/L2000**
 Bush, cabin **TGA/TGL/TGM**
 Bague **14x30x48**

KTK No.	RF No.	Bezeichnung Description Désignation	Erläuterungen Remarks Remarques
16722	 4 057822 167226		
		85 41723 6020 Hydraulikpumpe 85 41723 6011 Cabin pump RH 85 41723 6044 Pompe de levage de cabine	TGA/TGX/TGS
19437	 4 057822 194376		
		85 41723 6021 Hydraulikpumpe 85 41723 6014 Cabin pump LH 85 41723 6043 Pompe de levage de cabine	TGA/TGX/TGS

KTK No.		RF No.	Bezeichnung Description Désignation	Erläuterungen Remarks Remarques
---------	--	--------	---	---------------------------------------

19797





























81 62641 6080 Türgriff, rechts
 81 62641 6074 Door handle, RH
 81 62641 6078 Poignée de porte, droite















19798



























81 62641 6081 Türgriff, links
 Door handle, LH
 Poignée de porte, gauche









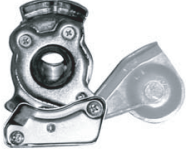

KTK No.	RF No.	Bezeichnung Description Désignation	Erläuterungen Remarks Remarques
21845	 4 057822 218453	 	81 62640 6057 Fensterheber, links Window regulator, Left Lève-vitre, gauche
21846	 4 057822 218462	 	81 62640 6058 Fensterheber, rechts Window regulator, Right Lève-vitre, droite
21844	 4 057822 218447	 	81 62640 6056 81 62640 6046 81 62640 6050 Fensterheber, rechts Window regulator, Right Lève-vitre, droite TGA
21843	 4 057822 218430	 	81 62640 6055 81 62640 6045 81 62640 6049 Fensterheber, links Window regulator, Left Lève-vitre, gauche TGA

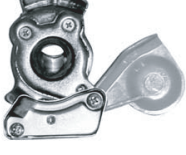

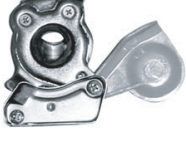

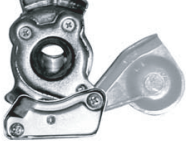



KTK No.	RF No.	Bezeichnung Description Désignation	Erläuterungen Remarks Remarques
22563	 4 057822 225636		
 	81 41722 6013	Kabinenstoßdämpfer Shock absorber Amortisseur de cabine	F 90, M/F 2000
22800	 4 057822 228002		
 	81 41722 6057	Kabinenstoßdämpfer Shock absorber Amortisseur de cabine	TGA/TGX
22799	 4 057822 227999		
 	81 41722 6051 81 41722 6048	Kabinenstoßdämpfer Shock absorber Amortisseur de cabine	F2000/TGA
22798	 4 057822 227982		
 	81 41722 6052 81 41722 6049	Kabinenstoßdämpfer Shock absorber Amortisseur de cabine	F 90, M/F 2000 TGA
22797	 4 057822 227975		
 	81 43701 6600 81 43701 6598 81 43701 6612 81 43701 6633	Kabinenstoßdämpfer Shock absorber Amortisseur de cabine	M/F 90, M/F 2000





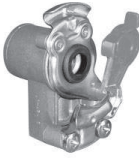









KTK No.	RF No.	Bezeichnung Description Désignation	Erläuterungen Remarks Remarques
22796	 4 057822 227968		
		85 41722 6014 Kabinenstoßdämpfer 85 41722 6022 Shock absorber 81 41722 6077 Amortisseur de cabine	TGA
22795	 4 057822 227951		
		85 41722 6015 Kabinenstoßdämpfer 81 41722 6078 Shock absorber 85 41722 6009 Amortisseur de cabine	TGA
22651	 4 057822 226510		
		85 41722 6017 Kabinenstoßdämpfer Shock absorber Amortisseur de cabine	TGA
22649	 4 057822 226497		
		81 41722 6012 Kabinenstoßdämpfer Shock absorber Amortisseur de cabine	F 90, M/F 2000
22650	 4 057822 226503		
		85 41722 6011 Kabinenstoßdämpfer Shock absorber Amortisseur de cabine	TGA



KTK No.	RF No.	Bezeichnung Description Désignation	Erläuterungen Remarks Remarques
08861	 4 057822 088613		
		81 96340 0278 Luftspirale Air hose - Red Spirale pneumatique	M16x1.5
08862	 4 057822 088620		
		81 96340 0279 Luftspirale Air hose - Yellow Spirale pneumatique	M16x1.5
08863	 4 057822 088637		
		81 96340 0238 Luftspirale Air hose - Red Spirale pneumatique	M22x1.5
08864	 4 057822 088644		
		Luftspirale Air hose - Yellow Spirale pneumatique	M22x1.5
08865	 4 057822 088651		
		Luftspirale Air hose - Red Spirale pneumatique	R 1/2"











KTK No.	RF No.	Bezeichnung Description Désignation	Erläuterungen Remarks Remarques
08866	 4 057822 088668	 Luftspirale Air hose - Yellow Spirale pneumatique	R 1/2"
08869	 4 057822 088668	 81 51220 6068 81 51220 6066 81 51220 6039 81 51220 6031	Kupplungskopf M16x1.5 Palm coupling Automatic - Red Main d'accouplement
08870	 4 057822 088705	 81 51220 6027 81 51220 6093	Kupplungskopf M16x1.5 Palm coupling Automatic - Yellow Main d'accouplement
08873	 4 057822 088736	 81 51220 6024	Kupplungskopf M22x1.5 Palm coupling Automatic - Red Main d'accouplement
08874	 4 057822 088743	 81 51220 6025	Kupplungskopf M22x1.5 Palm coupling Automatic - Yellow Main d'accouplement











KTK No.		RF No.	Bezeichnung Description Désignation	Erläuterungen Remarks Remarques
08867	 4 057822 088675			
		81 52220 6075 81 51220 6072 81 51220 6049	Kupplungskopf Air hose coupling Ordinary-Red Main d'accouplement	M16x1.5
08868	 4 057822 088682			
		81 51220 6043 81 51220 6040 81 51220 6038	Kupplungskopf Air hose coupling Ordinary-Yellow Main d'accouplement	M16x1.5
08871	 4 057822 088712			
		81 61220 6024	Kupplungskopf Air hose coupling Ordinary-Red Main d'accouplement	M22x1.5
08872	 4 057822 088729			
		81 51220 6033	Kupplungskopf Air hose coupling Ordinary-Yellow Main d'accouplement	M22x1.5
06942	 4 057822 069421			
		81 51270 6001	Ersatzgummi, Kupplungskopf Air Hose Coupling Rubber Caoutchouc de rechange, tête d'embrayage	















KTK No.	RF No.	Bezeichnung Description Désignation	Erläuterungen Remarks Remarques
07539	 4 057822 075392		
		Ersatzgummi, Kupplungskopf Flat type Air Hose Coupling Rubber Caoutchouc de rechange, tête d'embrayage	
13319	 4 057822 133191		
		81 99806 2076 Kupplungskopf Palm coupling - Red Main d'accouplement	M16x1.5
13320	 4 057822 133207		
		81 998062077 Kupplungskopf - Gelb Palm coupling - Yellow Main d'accouplement	M16x1.5















KTK No.	RF No.	Bezeichnung Description Désignation	Erläuterungen Remarks Remarques
08854	 4 057822 088545		
		04 35160 9704 Polyamidrohr Nylon pipe Tube de nylon	4x1 mm 25 Mtr Roll
08855	 4 057822 088552		
		04 35160 9706 Polyamidrohr Nylon pipe Tube de nylon	6x1 mm 25 Mtr Roll
08856	 4 057822 088569		
		04 35160 9207 Polyamidrohr Nylon pipe Tube de nylon	8x1 mm 25 Mtr Roll
08857	 4 057822 088576		
		Polyamidrohr Nylon pipe Tube de nylon	10x1.25 mm 25 Mtr Roll
08858	 4 057822 088583		
		Polyamidrohr Nylon pipe Tube de nylon	11x1.50 mm 25 Mtr Roll











KTK No.	RF No.	Bezeichnung Description Désignation	Erläuterungen Remarks Remarques
08859			
	04 35160 9812	Polyamidrohr Nylon pipe Tube de nylon	12x1.50 mmt 25 Mtr Roll
08860			
		Polyamidrohr Nylon pipe Tube de nylon	15x1.50 mm 25 Mtr Roll
14250			
		Polyamidrohr Nylon pipe Tube de nylon	16x2 mm 25 Mtr Roll

KTK No.	RF No.	Bezeichnung Description Désignation	Erläuterungen Remarks Remarques
07781	 4 057822 077815	 Reparatursatz Fitting sets for tube Kit de réparation	4 x 1mm
07782	 4 057822 077822	 Reparatursatz Fitting sets for tube Kit de réparation	6 x 1mm
07783	 4 057822 077839	 Reparatursatz Fitting sets for tube Kit de réparation	8 x 1mm
07784	 4 057822 077846	 Reparatursatz Fitting sets for tube Kit de réparation	10 x 1mm
07785	 4 057822 077853	 Reparatursatz Fitting sets for tube Kit de réparation	12 x 1.5mm















KTK No.	RF No.	Bezeichnung Description Désignation	Erläuterungen Remarks Remarques
07786	 4 057822 077860	 Reparatursatz Fitting sets for tube Kit de réparation	15 x 1.5mm
07766	 4 057822 077662	 Union nut	6mm M 12 x 1.5
07767	 4 057822 077679	 Union nut	8mm M 14 x 1.5
07768	 4 057822 077686	 Union nut	10mm M 16 x 1.5
07769	 4 057822 077693	 Union nut	12mm M 18 x 1.5















KTK No.	RF No.	Bezeichnung Description Désignation	Erläuterungen Remarks Remarques
07770	 4 057822 077709		
		Union nut	15mm M 22 x 1.5
07771	 4 057822 077716		
		Outer sleeve	6mm
07772	 4 057822 077723		
		Outer sleeve	8mm
07773	 4 057822 077730		
		Outer sleeve	10mm
07774	 4 057822 077747		
		Outer sleeve	12mm











KTK No.	RF No.	Bezeichnung Description Désignation	Erläuterungen Remarks Remarques
07775	 4 057822 077754		
		Outer sleeve	15mm
07776	 4 057822 077761		
		Sleeve insert	6mm
07777	 4 057822 077778		
		Sleeve insert	8mm
07778	 4 057822 077785		
		Sleeve insert	10mm
07779	 4 057822 077792		
		Sleeve insert	12mm













KTK No.	RF No.	Bezeichnung Description Désignation	Erläuterungen Remarks Remarques
07780	 4 057822 077808	 Sleeve insert	6mm
07765	 4 057822 077655	 Copper washer	6x10x1 6mm
07764	 4 057822 077648	 Copper washer	8x11.5x1 8mm
06511	 4 057822 065119	 Copper washer	10x14x1.5 10mm
06512	 4 057822 065126	 Copper washer	12x17x1.5 12mm















KTK No.	RF No.	Bezeichnung Description Désignation	Erläuterungen Remarks Remarques
06513	 4 057822 065133		
		Copper washer	14x20x1.5 14mm
06514	 4 057822 065140		
		Copper washer	16x22x1.5 16mm













KTK No.	RF No.	Bezeichnung Description Désignation	Erläuterungen Remarks Remarques
07285	 4 057822 072858		
 		Fitting automatic	4 mm Tube
07286	 4 057822 072865		
 		Fitting automatic	6 mm Tube
07287	 4 057822 072872		
 		Fitting automatic	8 mm Tube
07288	 4 057822 072889		
 		Fitting automatic	10 mm Tube
07289	 4 057822 072896		
 		Fitting automatic	12 mm Tube









KTK No.	RF No.	Bezeichnung Description Désignation	Erläuterungen Remarks Remarques
19161	 4 057822 191610		
 		Fitting automatic	16 mm Tube
07290	 4 057822 072902		
 		Fitting automatic	6 mm Tube
07291	 4 057822 072919		
 		Fitting automatic	8 mm Tube
07292	 4 057822 072926		
 		Fitting automatic	10 mm Tube
07293	 4 057822 072933		
 		Fitting automatic	12 mm Tube











KTK No.	RF No.	Bezeichnung Description Désignation	Erläuterungen Remarks Remarques
07294	 4 057822 072940	 Fitting automatic	4 mm Tube
07295	 4 057822 072957	 Fitting automatic	6 mm Tube
07296	 4 057822 072964	 Fitting automatic	8 mm Tube
07297	 4 057822 072971	 Fitting automatic	10 mm Tube
07298	 4 057822 072988	 Fitting automatic	12 mm Tube









KTK No.	RF No.	Bezeichnung Description Désignation	Erläuterungen Remarks Remarques
07299	 4 057822 072995	Fitting automatic reducer	4x6 mm Tube
	 		
07300	 4 057822 073008	Fitting automatic reducer	6x8 mm Tube
	 		
07301	 4 057822 073015	Fitting automatic reducer	8x10 mm Tube
	 		
07302	 4 057822 073022	Fitting automatic reducer	10x12 mm Tube
	 		

KTK No.	RF No.	Bezeichnung Description Désignation	Erläuterungen Remarks Remarques
21776	 4 057822 217761	Copper fitting	6mm
 			
21777	 4 057822 217778	Copper fitting	8mm
 			
21778	 4 057822 217785	Copper fitting	10mm
 			
21779	 4 057822 217792	Copper fitting	12mm
 			
21780	 4 057822 217808	Copper fitting	15mm
 			

KTK No.	RF No.	Bezeichnung Description Désignation	Erläuterungen Remarks Remarques
21781	 4 057822 217818		
		Copper fitting	16mm
21782	 4 057822 217825		
		Copper fitting	1/4"
21783	 4 057822 217832		
		Copper fitting	3/8"
21784	 4 057822 217849		
		Copper fitting	1/2"

KTK No.	RF No.	Bezeichnung Description Désignation	Erläuterungen Remarks Remarques
08235	 4 057822 082352	Hydraulic jack	20 TON
			
08218	 4 057822 082185	Hydraulic jack	30 TON
			
08219	 4 057822 082192	Hydraulic jack	50 TON
			

KTK No.	RF No.	Bezeichnung Description Désignation	Erläuterungen Remarks Remarques
08378	 4 057822 083786	 5-core cable	1 Roll 30met.
08377	 4 057822 083779	 7-core cable	1 Roll 30met
07157	 4 057822 071578	 7-core cable 6C x 1.5sq + 1C x 2sq	1 Roll 100met
20897	 4 057822 208974	 3 core cable	100 Mtr Roll
20898	 4 057822 208974	 2 core cable	100 Mtr Roll

KTK No.	RF No.	Bezeichnung Description Désignation	Erläuterungen Remarks Remarques
07158	 4 057822 071581	 Battery cable Black Flexible copper	50 mm Sq. 1 Rolle 25met.
08375	 4 057822 083755	 50mm Battery Cable	Red
07159	 4 057822 071592	 70mm Battery cable Black Flexible copper	70 mm Sq. 1 Rolle 25met.
08376	 4 057822 083762	 70mm Battery Cable	Red